

Unit 4

Mississippi River at Work

Unit 4: Mississippi River at Work builds on the knowledge and skills learned in Units 1, 2, and 3 to explore how humans rely on the river for more than just sustenance (food and water). This unit introduces students to human uses, beliefs, and values of the river and focuses on the river as a vital lifeline for human commerce and migration in the past, present, and future. The virtual river trip activity is used throughout this unit along with the wall map.

Having learned about how people used the river for transportation and trade in the past in Unit 3, students compare and contrast those uses with how people use the river today, including recreation and tourism. This helps prepare students for the activities in Unit 5.

4.0 Introduction to the Mississippi River at Work: Pre- and Post-Assessments

Students research river-related occupations and gain an understanding of the many different industries that use the Mississippi River. They read biographies of workers and interview people about their current jobs and career paths.

4.1 Early Navigation: Powered by People

Explore what river navigation was like before the Steam Age. Students learn about different types of boats and understand the skill and strength needed to maneuver them up and down the river. They make a flatboat and imagine life on the river before the Age of Steam.

4.2 All Aboard the Steamboat Era: Steam Powers a New Economy

Learn how the steamboat changed travel and commerce on the river and mark the twain with Samuel Clemens. Experiment with the power of steam and understand how it revolutionized travel on the Mississippi River.

4.3 River Running Dry, River Running High: Major Floods on the Upper Mississippi River

Explore the changeable Upper Mississippi River as it alternates between flooding and drought. Students write their own newscast to inform their communities of the reasons for floods and droughts and what they can do to live in harmony with the Upper Mississippi River.

4.4 Controlling the River: Locks and Dams on the Upper Mississippi

Analyze how locks and dams made the Upper Mississippi River the ultimate travel corridor by creating your own lock system and playing the role of lockmaster.

4.5 To Market! To Market! Our Inland Waterway System

Explore the role of the Mississippi River as part of the Inland Waterway system and its role as a vital economic artery. Students read a navigation chart and plan a journey from the Atlantic Ocean through the St. Lawrence Seaway to the Gulf of Mexico.

Introduction to the Mississippi River at Work



Unit 4 goal

Explore the Mississippi River at work and how it has changed over time

Lesson goal

Research river-related occupations on the Mississippi River

Lesson objectives

- Introduce the Mississippi River at work
- Identify river occupations
- Discuss the river's role in these occupations
- Write about an occupation of your choosing

Educational standards

- Social Sciences
- Fine Arts
- Language Arts

What you'll need

- *Confluence: The River Heritage of St. Louis* video

How long it will take

- *Activity 1*: 15 min.
- *Activity 2*: 2 hrs.

What's next!

Go back in time and learn about early navigation on the river

Introduction

Students research river-related occupations on the Mississippi River and gain an understanding of the many industries that rely on the Mississippi River. They read biographies of workers and interview people about their current jobs and career paths.



Most of the activities and discussions in Unit 4 relate to social studies and language arts standards. Students continue to develop their research skills by learning about river-related occupations and then practice their communication skills by writing about the job they find most interesting.

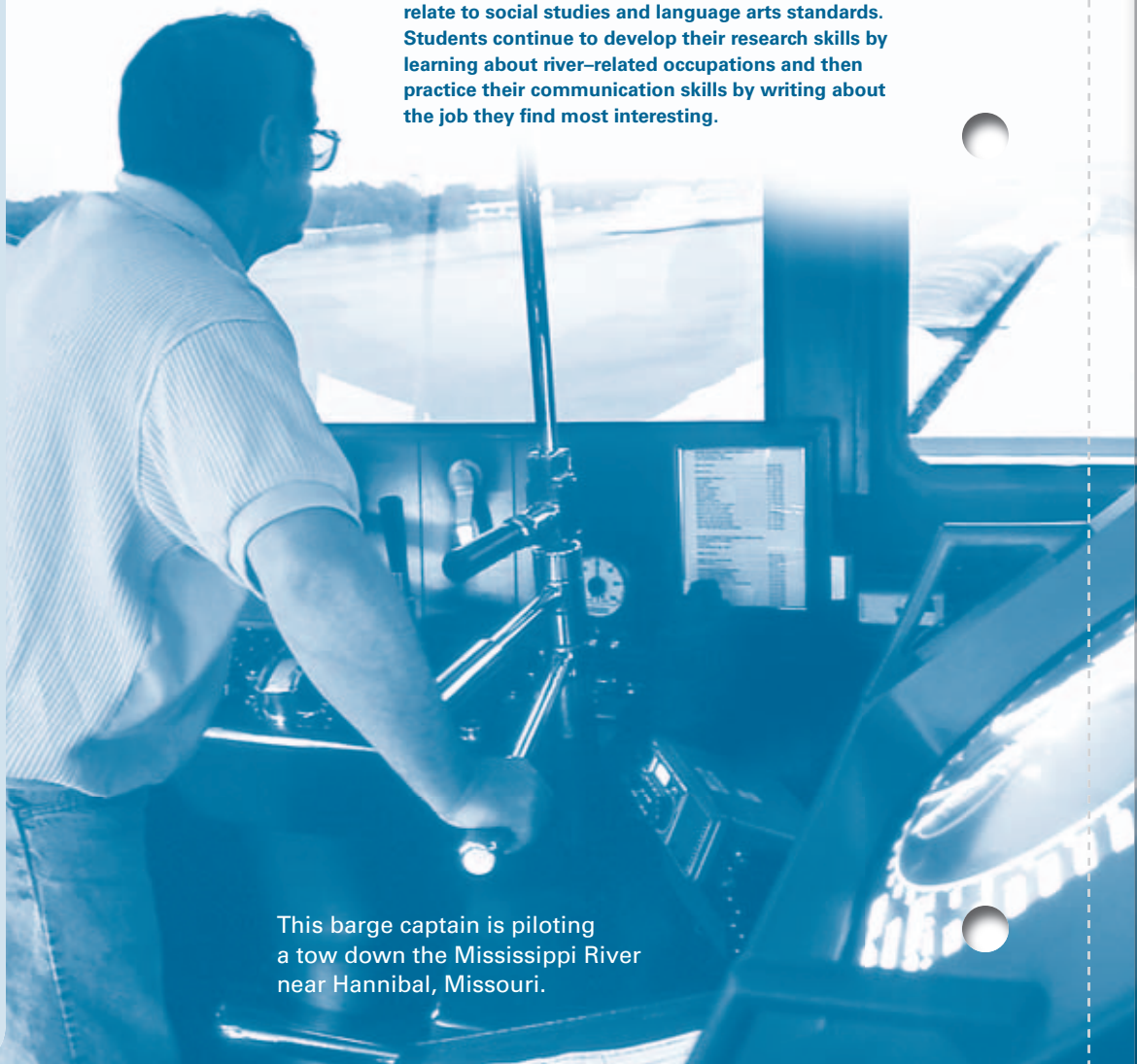

This barge captain is piloting a tow down the Mississippi River near Hannibal, Missouri.



15 MINUTES

What you'll need

- Activity worksheet (page 216–217)

Pre- and Post-Assessment

Instructions

1. Copy and distribute the Pre- and Post-Assessment activity worksheet on the following pages.
2. Allow 15 minutes for students to complete the assessment.
3. Save the pre-assessments to compare with a post-assessment given after students complete all the lessons in this unit using this same activity worksheet.
4. Calculate each student's percent increase in knowledge.

Answer Key



Multiple choice

1. B 2. A 3. C 4. B 5. D 6. C 7. D 8. C 9. B 10. False

Work Songs

Work songs were sung while conducting a task to direct physical labor and synchronize the timing.

(VERSE)

*I hear dat bell a-ringing,
I see de Captain stand,
Boat done blow'd her whistle,
I know she's gwine to land.
I hear de mate a callin',
"Go git out the plank,
Rush out wid de headline,
An' tie her to de bank."*

(CHORUS)

*Roll out! heave dat cotton
Roll out! heave dat cotton
Roll out! heave dat cotton,
ain't got long to stay.*

(VERSE)

*It's early in de morning,
Before we see de sun,
"Roll aboard dat cotton,
An' get back in a run."
De Captain's in a hurry,
I know what he means,
Wants to beat de Sherlock,
Down to New Orleans.*

(CHORUS)**(VERSE)**

*I heard dat mate a-shouting,
An' see him on de shore,
"Hurry boys! be lively,
Ain't but fifty more."
We ain't got time to tarry,
Here at dis cotton pile,
We gwine to git annoder,
Below here forty miles.*

-William Shakespeare Hays
(1837 – 1907), American poet
and lyricist



Unit 4 Assessment

Name _____ Date _____

Multiple choice

Circle the correct answer.

1. Who invented the steamboat?
 - a. Mark Twain
 - b. John Fitch
 - c. Daniel Grayson
 - d. Zebulon Pike

2. How many cords of wood per day did the average steamboat use in the 1880s?
 - a. 15-75 cords of wood a day (enough to build 15 houses)
 - b. 5-10 cords of wood a day (enough to build 5 houses)
 - c. 100-125 cords of wood a day (enough to build 20 houses)
 - d. 130-150 cords of wood a day (enough to build 25 houses)

3. The first lock was built to deal with:
 - a. floods
 - b. sediment
 - c. rapids
 - d. fish

4. Besides being a writer, Mark Twain was also a:
 - a. lock builder
 - b. steamboat captain
 - c. railroad engineer
 - d. river guide

5. One 15-barge tow carrying dry goods on the river can replace:
 - a. 2 trucks or 1 rail car
 - b. 35 trucks or 8 rail cars
 - c. 70 trucks or 16 rail cars
 - d. 870 trucks or 225 rail cars



6. 9-foot channel:
 - a. Minimum distance required between barges
 - b. A subspecies of the channel catfish
 - c. Depth of the river needed for barges to navigate the river
 - d. Length of a channel boat

7. Which of these industries utilize the Mississippi River?
 - a. Agriculture
 - b. Transportation
 - c. Tourism
 - d. All of the above

8. What percentage of grain exported in the United States is shipped via the Mississippi River?
 - a. 20%
 - b. 40%
 - c. 60%
 - d. 80%

9. Approximately how many tons of goods were shipped via the Mississippi River in 2005?
 - a. 100 million tons
 - b. 500 million tons
 - c. 750 million tons
 - d. 250 million tons

10. There are 14 locks on the Mississippi River.
 - a. True
 - b. False

Background

No river has played a greater part in the development and expansion of America than the Mississippi. Our nation's chief navigable water route, it was – and still is – a vital factor in the physical and economic growth of this country. It is a place where people live, work, and play.

The Mississippi River Watershed includes some of our nation's most productive agricultural and industrial regions. Agriculture has been the primary user of the lands in the Mississippi River Watershed, continually altering the hydrologic cycle and energy budget of the region. Barges and towboats on the

Mississippi River System carry 60% of the agricultural goods, industrial products, and raw materials transported on inland waterways.

Because of the Upper Mississippi River's slow current and relative depth, a series of locks and dams were built on the river in the 19th and 20th centuries to facilitate navigation for a steady stream of barge traffic. Most of the Mississippi River's big tributaries – the Missouri, Illinois, and Ohio Rivers – have also been developed for navigation.

Source: U.S. Army Corps of Engineers

A ranger at work

Fast Facts

- ◆ Nearly 500 U.S. grain transfer facilities are served by water transportation with the largest number, over 140 facilities, located on the Upper Mississippi River and the Illinois Waterway.
- ◆ Mississippi River Basin produces 92% of the nation's agricultural exports, 78% of the world's exports in feed grains and soybeans, and most of the livestock and hogs produced nationally.
- ◆ At least 40% of all North American migratory waterfowl depend on the Mississippi River Flyway during their spring and fall migrations.
- ◆ About 60% of all grain exported from the U.S. is shipped via the Mississippi River through the Port of New Orleans and the Port of South Louisiana.
- ◆ The Port of South Louisiana which stretches 54 miles along the Mississippi River is the largest tonnage port in the United States. It is comprised of facilities in St. Charles, St. John the Baptist, and St. James Parishes. Primary outbound cargoes include corn, animal feed, wheat, and soybean. (2009 information)
- ◆ Products shipped (partial list):
 - petroleum and petroleum products
 - iron and steel
 - grain including wheat, corn, and soybean
 - rubber
 - paper and wood
 - coffee
 - coal
 - chemicals



A farmer at work



A forester at work



Commercial fishermen at work

Introduction 4.0



Career Launch

Careers and occupations related to the Mississippi River Watershed

- **Agriculture:** corn, wheat, rice, soybeans, chicken, hogs, beef and dairy cattle
- **Biologists:** fish and wildlife
- **Forestry:** logging, paper products
- **Commercial fishing:** operators, construction folks, facility engineers
- **Commercial watercraft:** captains and crew
- **Conservation:** public education, habitat protection and restoration
- **Dock operators and crew**
- **Ecosystem monitoring**
- **Energy production and distribution**
- **Engineering**
- **Habitat restoration**
- **Lock and dam:** facility operators, construction workers, engineers
- **Manufacturing:** food processing, machinery, transportation equipment, and chemicals
- **Merchant mariners:** operate and maintain tugboats, dredges, towboats, ferries, merchant ships, excursion vessels
- **Mining:** crushed stone, coal, sand and gravel, cement, and lime production
- **Recreation and tourism:** restaurants and hotels, river guides, recreation equipment, visitor centers, lifeguards
- **Park rangers**
- **Wildlife managers**

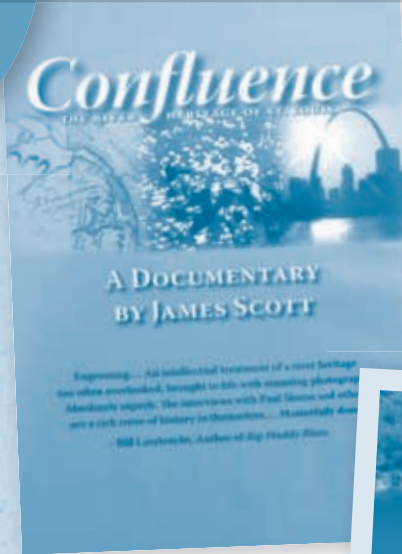

Produced and directed by Professor James Scott at St. Louis University, *Confluence: The River Heritage of St. Louis* is available for purchase from the National Great Rivers Museum gift shop and online at www.booksonstlouis.com.



Discussion (60–90 minutes)

Let's explore the river at work!

To spark student interest, watch the dynamic opening scene of the video *Confluence: The River Heritage of St. Louis*, which shows a variety of people working and recreating on the river.

Tell students that the Mississippi River is a working river and ask them what they think that means. Does the river have a job? Does the river earn money? Or does the river help us earn money by transporting our goods to market? Perhaps by providing us river jobs, like boat captain or river guide? Ask students what their parents do for a living. Do their occupations relate to the river?

Have students take 15 minutes to write down all the types of occupations they can think of that relate to the Mississippi River without using the Internet or books. Remind students that the Mississippi River Watershed encompasses 31 states (see Unit 1), so they should broaden their focus beyond jobs along the riverbank.



Mississippi River Watershed Occupations

Grades

5-6

Individual activity

2 HOURS

- 45 minutes to read and prepare lists
- 45 minutes to share and discuss
- 30 minutes to start essay (finish as homework)

What you'll need

- *Working on the Mississippi Activity* worksheets (pages 222-225)

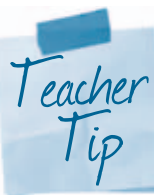

Refer to Career Launch section on the previous page and A1: Career Launch on page 312 to familiarize yourself with the different occupations related to the Mississippi River Watershed.

Get Ready

Ask students to:

- Read the statements by six people who work on the river.
- Brainstorm other river-related occupations and write down as many occupations related to the river as they can.

Do This

1. Conduct the class discussion described above and write student responses on the board.
2. Select several occupations and ask:
 - What role does the river play with these occupations? (i.e., water for farming, transportation for logs, etc.)
 - How have these occupations changed in the last 100 years?
3. Have the students choose which job sounds the most interesting.
4. Have the students write to someone with that job to ask questions about their career and day-to-day job.
 - Using that information, have students prepare a report about that occupation. The report should include visuals such as charts and graphs.
 - Have students create a PowerPoint presentation and show it to the class.



Working on the Mississippi River

Name _____ Date _____

Meet some of the people who have river-related careers and read about their jobs. Choose which job sounds the most interesting to you and research that occupation. Based on your research, brainstorm at least three questions you would like to ask. As a class, send one letter to that person requesting additional information.

Read Below



Christine Favilla

*Three Rivers Project
Coordinator*

Sierra Club, Illinois Chapter
223 Market Street
Alton, IL 62002
illinois.sierraclub.org

The Sierra Club is a non-profit, member-supported, public interest organization that seeks to practice and promote the responsible use of the earth's ecosystems and resources and to educate and enlist humanity to protect and restore the quality of the natural and human environment.

As the Three Rivers Project Coordinator, Christine Favilla helps to protect the region's big rivers, valuable wetlands, and tributaries. She reviews and comments on permits for development or the release of pollutants in the waterways. She is also active on several committees that work with landowners and government agencies to reach sustainable goals in their planning efforts.

" My vision for the upper Mississippi River is one that moves us from managing the river solely for our benefit to managing ourselves within the capacity of the river system. This strong sustainability goal includes a movement to local economies and local agriculture, resulting in less nutrient pollution, a smaller carbon footprint, and stronger communities. Working together, we can have healthier rivers, healthy economies, and healthier communities."

-Christine Favilla



Paul Rohde

Vice President

Waterways Council, Inc. (WCI)
225 South Meramec Avenue,
Suite 305
Saint Louis, MO 63105
www.waterwayscouncil.org

Waterways Council, Inc. (WCI) is the national public policy organization that advocates for a properly funded and well-maintained system of inland waterways and ports. As WCI Vice President, Paul Rohde seeks to educate decision-makers in the states and federal government, the news media and the general public about the critical importance of our nation’s inland waterway system and the need to sustain and increase its reliability now and for our future.

The inland waterways industry was created for commerce back when Lewis and Clark set out on their exploration of the river system in the early 1800s. Today, our inland waterways transportation system offers the most fuel efficient, environmentally sustainable method of moving our nation’s bulk commodities, at the lowest cost to shippers and, therefore, to everyone as consumers.

“ I work closely with environmental, conservation and recreation groups, as well as many other advocates, to discover ways our organizations can work together to benefit both the environmental and economic concerns on river issues. Affecting river policy is all about building coalitions – finding where groups can work together, rolling our sleeves up, and working to change the status quo.” - Paul Rohde



June Jeffries, PE

Project Manager

U.S. Army Corps of Engineers,
St. Louis District
Hydraulics Branch Engineering
and Construction Division
1222 Spruce St.
St. Louis, MO 63103
mvs-wc.mvs.usace.army.mil

June M. Jeffries, Professional Engineer, is the Chief of the Environmental Engineering Section at the St. Louis District, US Army Corps of Engineers. Her responsibilities include water quality, environmental services and lab analyses, industrial hygiene, HTRW (hazardous, toxic, or radioactive waste) activities, sanitary engineering.

She was formerly the project manager for the St. Louis District dike and revetment program and regulating works projects, which provided safe and dependable navigation channels on the Mississippi River, Kaskaskia River, and Illinois Waterway. She also managed programs to avoid and minimize impacts of navigation upon the environment.

June has 20 years engineering experience, with an undergraduate degree in mechanical engineering, and graduate degrees in civil/ environmental engineering, ecology, and manufacturing engineering. While at the Corps of Engineers, June has worked as a water control manager and as a project manager for flood risk management projects.

“ My job is a challenge that I enjoy meeting every day, and it is the best job I have ever had. My job allows me to work with people with a wide range of talents, for example with biologists, engineers, towboat pilots, and farmers. I very much enjoy opportunities to visit the river and see my projects in person.” - June Jeffries



Michael F. Clark
*Owner, River Guide
 and Outfitter*
 Big Muddy Adventures
 539 Scranton Avenue
 Riverview, MO 63137
 www.2muddy.com

Michael Clark has over 10,000 miles of experience as a river guide and outfitter. He also teaches history, science, and computer science at St. Ann's of Normandy in St. Louis.

As the owner of Big Muddy Adventures, Michael's mission has been to connect people of all ages to rivers and facilitate a lifelong love of learning through exploration. Since 2001, he has guided groups on the Mississippi and Missouri Rivers and conducted live learning adventures for school children across the country.

Michael also lends his talents and equipment to numerous community service organizations to help clean the rivers. In 2009, Michael and his guides helped pull dozens of tires and barrels along with nearly a ton of plastic, aluminum, Styrofoam, metal, and cast iron from the rivers.

" The Mississippi River provides some of the best habitat in the world for a variety of species. Showing people some of the awesome places where nature remains intact and resilient is one of the keys to what we do."

- Michael F. Clark



Jeff Janvrin
*Fisheries Biologist/
 Mississippi River
 Habitat Specialist*
 Wisconsin Department
 of Natural Resources
 3550 Mormon Coulee Road,
 La Crosse, Wisconsin, 54601
 dnr.wi.gov

As a fisheries biologist and habitat specialist with the Wisconsin Department of Natural Resources, Jeff Janvrin's mission is to protect and enhance the river environment and to promote responsible use of river resources. He thinks of the health of the river from a larger perspective: habitat loss, endangered species, and sedimentation.

Jeff Janvrin coordinates the identification, selection, planning, implementation, and evaluation of Mississippi River habitat restoration projects along the Wisconsin border. This involves a collaboration of efforts with other states, government agencies, organizations, and individuals.

An important part of Jeff's job is the collection of data both before and after a project. This helps determine if project goals were met and documents lessons learned that can be used to improve future projects.

" Restoration of an ecosystem is much more complex than grabbing the keys to a bulldozer and starting to push things back into place. Habitat restoration requires careful planning and patience. In some respects, it is much like trying to figure out how to put a puzzle back together, only you don't necessarily have, or know, where all of the pieces are and where they go." - Jeff Janvrin



Matthew E. Schramm

Resource

Conservationist

Rock Island County Soil and Water Conservation District
3020 East 1st Ave.
Milan, IL 61264
www.aiswcd.org

Rock Island County Soil and Water Conservation District’s mission is to promote conservation of natural resources (soil, water quality, air, vegetation, and wildlife habitat) through delivery of a variety of programs to local landowners, the public, and public agencies.

As a resource conservationist, Matthew Schramm works with landowners and public agencies to coordinate conservation efforts to improve water quality and reduce soil erosion. He also manages projects that restore ecosystems and prevent wildfires.

Since the local watersheds in his district all drain into the Mississippi River, everything his agency does has the potential to affect its health and water quality. The communities in his district are shaped by the Mississippi River and its history, including the decisions made today.

“ One of the best parts of my job is working on collaborative efforts with other agencies, partners, and profession colleagues to advance local conservation of natural resources. Money, staff resources, and time are at a premium these days, but it is really neat to see what we can accomplish when we sit down together and work towards a set of common goals and objectives.” - Matthew E. Schramm

Write down the three questions that your class would like to ask in the letter.



The Mississippi River Water Trail is being developed by the U.S. Army Corps of Engineers and partnering organizations

in response to public requests for a water trail on the Mississippi River within the St. Louis District boundary. The Corps has developed day use rest areas, primitive camping areas, watchable wildlife and interpretive opportunities on the Mississippi River.

The Mississippi River Water Trail was established through a partnership with the Mississippi River Water Trail Association, American Canoe Association, St. Louis Canoe and Kayak Club and numerous other partners to support and enhance the Mississippi River Water Trail and encourage community involvement. Visit www.greatriverwatertrail.org for more information.

Extension Suggestions



~ Career launch

Invite a local **career counselor** or **employment recruiter** to speak to the class. Ask students to research the field and prepare questions in advance. See *A1: Career Launch* on page 312 for career information and professional associations.

~ Get out!

- Just like in the old days, make a fishing pole from a long, sturdy stick, twine, and a hook. Go try it out. Learn which fish and size of fish you can keep, which you must throw back. Will you need a license to fish?
- **Job Shadow:** Students wrote an essay about an occupation they found interesting. Next they should try to job shadow someone doing that job.

~ Express yourself!

Create a Jeopardy-style game about river occupations and play as a class.

~ Grades K–4 Extension



What Floats, What Sinks?

In the classroom or outside, have students experiment with various items, such as a leaf, pencil, pebble, or chalk, to see which ones float or sink in water.

Welcome to Our Mississippi

File Edit View Favorites Tools Help



<http://www.OurMississippi.org>

~ Learn more online

Learn about the **U.S. Department of Labor (DOL)**. Go to www.dol.gov and read about occupations in the U.S. by searching keywords **list of SOC occupations**

Explore green jobs at the **U.S. Department of Labor (DOL)**. Go to www.dol.gov and search keywords **good jobs, safe jobs, green jobs**

Visit the **U.S. Army Corps of Engineers** (www.usace.army.mil) Search keywords: **Navigation, History, and Occupations**

Early Navigation:

Powered by People

Introduction

In *Lesson 4.1*, students learn about the types of boats used on the Upper Mississippi River before the Steam Age and how they were navigated. Students read about the exploits of the King of the Keel-boaters and understand the skill and strength

needed to maneuver a Keelboat up and down the river. Students also make a flatboat and imagine life on the river before the Steam Age.

Most of the activities and discussions in Unit 4 relate to social studies and language arts standards. Students continue to develop their research skills by learning about river-related occupations and then practice their communication skills by writing about the job that they find most interesting.

STANDARDS CORRELATION

Mike Fink King of the Keelboaters

Mike Fink (born 1770/1780? – died 1823) was a legendary boatman who exemplified the tough men who ran keelboats up and down the Ohio and Mississippi Rivers. The son of French Canadians, he was born in Fort Pitt, near Pittsburgh, PA. When he began his career in navigation he became notorious for both for his practical jokes and

his willingness to fight anyone who was not amused. The muscles required to force a keelboat upstream would have made him a formidable opponent. Davy Crockett is supposed to have described him as “half horse and half alligator.”



~ Unit 4 goal reminder

Explore the Mississippi River at work and how it has changed over time

~ Lesson goal

Explore what river navigation was like before the Age of Steam

~ Lesson objectives

- Compare watercraft used before steamboats
- Understand how early watercraft were navigated
- Build a flatboat

~ Educational standards

- Social Studies
- Fine Arts
- Language Arts

~ What you'll need

- *Confluence: The River Heritage of St. Louis* video
- Pen and paper
- Metronome or other instrument to keep time
- 1 half-gallon milk or juice carton
- Ruler
- Scissors
- Tape
- Pipe cleaners
- Paper clips
- Water
- Toy people or animals, popcorn, and pennies

~ How long it will take

- *Discussion*: 60 min.
- *Activity 1*: 30 min.
- *Activity 2*: 60 min.

~ What's next!

Let's STEAM down the Mississippi River

Lesson 4.1



Lt. Robert E. Lee mapped the Rock Island rapids in 1837. He proposed cutting off the rock projections in the natural channel to make passage easier and less dangerous.

Background

Before the locks and dams, the Upper Mississippi River was a natural, meandering river filled with shifting sand bars and shallow areas. Starting at Lake Itasca in north-central Minnesota, the Upper Mississippi flows more than 500 miles before it becomes navigable near St. Paul, Minnesota. From there, it flows 670 miles south to St. Louis. Along the way, the Upper Mississippi is fed by several rivers including the Minnesota, St. Croix, Chippewa, Wisconsin, Rock, Des Moines, and Illinois Rivers.

At places such as the Des Moines and Rock Island Rapids, the river's current could be dangerously swift and treacherous, depending on water levels. The depth of the Upper Mississippi averaged approximately three feet and, at certain seasons, amounted to as little as one foot in the 200

miles below St. Paul. During times of flooding, the Upper Mississippi was deep but turbulent. More frequently, long dry spells made the river too shallow to navigate. In addition, the river's uncharted shoals and sand bars presented a constant danger. Equally dangerous were the snags, debris, and trees that storms had washed from the river's banks into its waters.

Just above St. Louis the Mississippi River joins with the Missouri River, where it gains strength and volume. About 170 miles south of St. Louis at Cairo, Illinois, the Mississippi River meets with the Ohio River and doubles its volume. At this point, it becomes the Lower Mississippi, that "mile-wide tide, shining in the sun" described by Mark Twain.

Navigating the Upper Mississippi River

The Upper Mississippi was a challenge to all who traveled its waters. For hundreds of years before the Steam Age, small, light-draft craft plied the Upper Mississippi. Native Americans used boats that were adaptable to the river's shallow depth and variable conditions, such as canoes and pirogues, made out of hollowed-out logs. These could be either paddled or poled, depending on the depth of the water.

Whatever the craft, its success depended upon the river's ever-changing conditions, and the skill of its pilot. Early navigators were constrained by the natural routes and depths of the waterways they traveled. Where they met shallow water or rapids in rivers, they were forced to portage, or carry, their goods and boats around the obstruction before continuing their journey.



Flatboats and keelboats

Flatboat: A flatboat was a rectangular flat-bottomed boat used to transport freight and passengers on inland waterways. The flatboat is essentially a large, sturdy tub with a hull that displaces water and so floats in the water (which differentiates it from a raft, which floats on the water).

Flatboats were rowed or pulled by horses that walked the river on a road called the towpath.

Loaded at an upstream point, they were floated downriver where their cargoes were unloaded. The flatboats were then dismantled and sold for lumber. Built for one trip only, they were cheap and often poorly constructed, but carried large quantities of merchandise at a time.

Keelboat: The most sophisticated craft on the Upper Mississippi prior to the arrival of the steamboat was the keelboat, which came into use sometime before 1800. Long, with narrow, graceful lines, the keelboat was the first queen of the river trade.

Two-way travelers, keelboats were built to survive many trips and could carry as much as 80 tons of freight. These shallow-draft, flat-bottom vessels were pointed at both ends, which allowed them to be poled or pulled upstream. Lieutenant Zebulon M. Pike and his men used a 70-foot keelboat during their exploration of the Upper Mississippi River Valley in 1805.

Sources: U.S. Army Corps of Engineers and the National Park Service

Lesson 4.1



Discussion (60 minutes)

Show students the “The Primal River Network” scene from the video *Confluence: The River Heritage of St. Louis*.

Discuss what was learned, focusing on how people used the river before the Steam Age (trade and migration). Produced and directed by Professor James Scott at St. Louis University, this video is available for purchase from the National Great Rivers Museum gift shop and online at www.booksonstlouis.com.

Describe the history of the different types of boats used on the river and how they were navigated. What types of watercraft did the Native Americans use? What role did the river play in the lives of Native Americans? What types of boats were used by the explorers and why? What kind did Lewis and Clark use?

Ask the students to think back to the last unit. What are the similarities among modern and historic boats? Prompt students to compare flatboats with today's barges.

What Kind of Boat Was Used?

Type of Boat	Typical Cargo and Cargo Limits	Size and Crew	Direction and Power	When Used
 Canoe (birch bark or dugout)	Up to 2.5 tons: Food, furs, hides, travel supplies	About 18'x3'; Crew 1-13	Upstream: paddles Downstream: current	Prehistory to early 1800s
 Pirogue (Pee'row)	Up to 40 tons: Food, furs, hides, dry goods, cloth, blankets, military and travel supplies	Largest 50'x5'; Crew up to 30	Upstream: oars or poles Downstream: current	1660s – 1860s
 Bateau	Up to 40 tons: Passengers, dry goods, cloth, blankets, military and travel supplies	Larger than a pirogue; Crew of 18–30	Upstream: oars or poles Downstream: current	1750s – 1790s
 Log Raft	Lumber and logs, which was the log raft itself, sold at destination	About 600' long, 7–20' wide; Crew of 20	Downstream only: current	1830s – 1915
 Flatboat	Up to 100 tons: Settlers with livestock and household goods and supplies, agriculture (apples, potatoes, sugar), coal, general merchandise	Varied widely	Downstream only: current	1740s – 1870s
 Keelboat	15 – 100 tons: food, furs, military equipment, travel supplies, passengers, agriculture (apples, potatoes, sugar), coal, general merchandise	30–100 long, 7–20' wide; Crew of 10	Upstream: pushed by poles or pulled from shore, sometimes sail; Downstream: current	1770s – 1860s



Grades
5-6

Small group
(3 students) activity

30 MINUTES

Row, Tow, or Pole Your Boat

Some believe the song “Row, Row, Row Your Boat” is a work song. Rowing is a skillful, if tedious, practice that takes precision to power and steer a vessel. When a work song is sung as a group, it becomes a unifier, helping to keep the rowing of the oars in sync. Some have suggested the lyrics are a metaphor for life’s difficult choices.

The most common modern version is:

*Row, row, row your boat,
Gently down the stream.
Merrily, merrily, merrily, merrily,
Life is but a dream.*



Sometimes people sing additional verses simply to extend the song, which is considered a form of children’s street culture.

Do This

1. Ask students to add verses that relate to navigating the Upper Mississippi River or teaching someone how to paddle a canoe (see page 226). For example:

*Row, row, row your boat
Gently down the stream
If you see a waterfall
Don't forget to scream*

*Row, row, row your boat
Gently down the lake
Don't stand up and rock the boat
That's a big mistake!*

*Rock, rock, rock your boat
Gently to and fro
Watch out, give a shout,
Into the water you go!*

2. Have students sing their verses as a round in class. Use a metronome to emphasize the importance of timing.

What you'll need

- Pen and paper
- Metronome or other instrument to keep time (if sung in class)



Teacher Tip
A round is a musical composition in which two or more voices sing exactly the same melody (and may continue repeating it indefinitely), but with each voice beginning at different times so that different parts of the melody coincide in the different voices, but nevertheless fit harmoniously together.

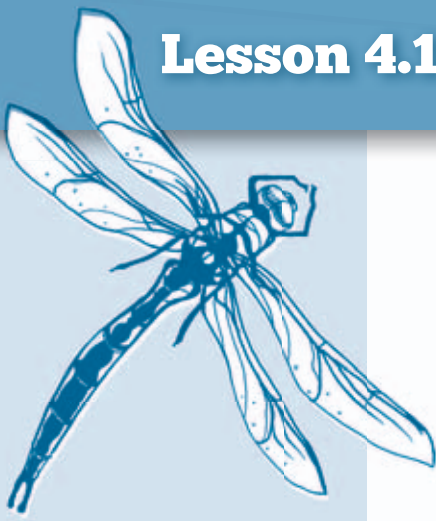

Float Your Boat

Grades
5-6

Class or small group activity

60 MINUTES

What you'll need

- 1 half gallon milk or juice carton (per student)
- Ruler
- Scissors
- Tape
- Pipe cleaners
- Paper clips
- Water to float your boat in
- Things to put in your boat: toy people or animals, popcorn, pennies



Fill a plastic bin or tub with water and test the boats a few at a time or take students outside to try their boats in a nearby stream or pond.

Students build and test their flatboats, both when empty and filled with cargo, such as popcorn, pennies, or small toy animals and people.

Here's how it works:



Open the top of the carton and make sure it is clean inside. Lay the carton on its side.



Draw a straight horizontal line the length of the carton, dividing it in half. Extend the line across the bottom of the carton, and then along the entire length of the other side.



Cut along the line, splitting the carton in half.



Cut along the diagonal folds down to the top of the carton. You should have three flaps, a wide one in the center and a small one on each side.

5



Fold the wide center flap upward to meet the sides. Cut off the center flap excess overlap.

6



Before you secure the flaps together with tape, this is what your flaps should look like. Secure each of the small flaps to the large one with tape.

7



Seal the edges of the flaps inside and out so your flatboat won't leak. You now have the hull of your flatboat.

8



Use the other carton half to make the cabin. Measure 3" from the bottom of the carton and draw a line across all four sides.

9



Cut off the bottom of the carton. You now have your cabin.

10



Cut small tabs (2 cuts $\frac{1}{2}$ " high and 1" apart) on all sides of the carton bottom.

11



Secure the cabin to the back of your flatboat with tape.

12



Paperclip a pipe cleaner to each side of the hull so that the crew will have something to propel the flatboat through the water.

13



Fill your boat with crew members or cargo, such as popcorn kernels or pennies.

Fast Facts

◆ In 1705, the first recorded cargo was floated down the river from the Indian country around the Wabash, now the states of Indiana and Ohio. This was a load of 15,000 bear and deer hides brought downstream and out below Baton Rouge on its way to France.



Extension Suggestions



~ Career launch

Invite a local **historian** to speak to the class. Ask students to research the field and prepare questions in advance. See *A1: Career Launch* on page 312 for career information and professional associations.

~ Express yourself!

- Write a play about traveling the Upper Mississippi River by canoe in the early 1800s.
- Read a Mark Twain book and write a book report to share with the class. Some books Twain wrote:
 - *Huckleberry Finn*
 - *Tom Sawyer*
 - *A Connecticut Yankee in King Arthur's Court*
 - *A Double Barrelled Detective Story*
 - *Captain Stormfield's Visit to Heaven*

~ Get out!

- Go float your boat that you made during Activity 1, pages 232–233.
- Visit a local marina and watch the watercraft in action.
- Take a hike at a nearby park and learn how to use a map and compass.
- Take safe canoeing lessons from the local parks and recreation department.

Welcome to Our Mississippi

File Edit View Favorites Tools Help



http://www.OurMississippi.org

~ Learn more online

Learn about fur traders' keelboats at [SteamboatTimes \(www.steamboattimes.com\)](http://www.steamboattimes.com). Choose the button **Keelboat** in the menu.

Before bridges were constructed, ferry boats were the way to cross the river. Learn about riverboats and the early ferry operations on the [Illinois State Museum website \(www.museum.state.il.us\)](http://www.museum.state.il.us). Enter keywords **first ferry** in the "Search ISM Site" box. Then click on **Early Technology; Riverboats and Ferry Operations**

Learn about ferry boats on the Middle Mississippi River today. Go to Greatriverroad.com and click the button **River Ferries**

All Aboard the Steamboat Era:

Steam Powers a New Economy

Introduction

In *Lesson 4.2*, students learn how the steamboat changed travel and commerce on the river. They use nautical charts and “mark the twain” with Samuel Clemens. A demonstration of the power of steam helps students understand how steam power revolutionized travel on the Mississippi River.

STANDARDS CORRELATION

In this lesson we continue to uncover ways to navigate the river and introduce the steamboat. We touch on the physical science standard as students watch a demonstration about the power of steam and address the history of science by learning about the inventors that harnessed it.

major transportation corridor, increased trade, and created a river culture that was distinctly American.

Since there were few roads and no railways in the lands of the Louisiana Purchase, the Mississippi River and its tributaries were the best routes for travel, trade, and settlement. With the advent of steam power, those activities increased dramatically. A voyage that once took months could now be done in ten days.

In 1811, the first steamboat to travel the Mississippi from the Ohio River to New Orleans was the *New Orleans*. She transported people and goods between New Orleans, Louisiana and Natchez, Mississippi until she hit a stump and sank two years later.

Background

The invention of the steamboat in the early 1800s changed life along the Mississippi River.

Steam-powered shipping turned the river into a

~ **Unit 4 goal reminder**
Explore the Mississippi River at work and how it has changed over time

~ **Lesson goal**
Learn how the steamboat changed travel and commerce on the river

~ **Lesson objectives**

- Introduce the steamboat
- Discuss how the steamboat revolutionized river commerce
- Use maps to navigate the river
- Demonstrate the power of steam

~ **Educational standards**

- Science
- Social Studies
- Fine Arts
- Language Arts

~ **What you'll need**

- *Confluence: The River Heritage of St. Louis* video
- 2 cups of water
- Toy pinwheel
- Hotpot or pot of boiling water and hot plate
- Pot-holder glove
- Cub pilot journal

~ **How long it will take**

- *Activity 1*: 30 min.
- *Activity 2*: 60 min.

~ **What's next!**
Floods and drought on the Upper Mississippi River.

Lesson 4.2

During the War of 1812, between the United States and Great Britain, Capt. Henry M. Shreve brought a cargo of supplies for Gen. Andrew Jackson's army from Pittsburgh to New Orleans in his side-wheeler, the *Enterprise*.

Although steamboats were in service between New Orleans and Natchez, they had not yet traveled far upriver. In 1817, the *Washington* made the round trip from Louisville to New Orleans in 41 days. Steamboat traffic increased rapidly soon after that. By 1833 more than 1,200 steamboats traveled the river.

Steamboats on the Upper Mississippi

In August 1817, the *Zebulon M. Pike* became the first steamboat to reach St. Louis after a six-week trip from Louisville, Kentucky. In 1823, the

Virginia was the first steamboat to travel from St. Louis, Missouri, to St. Paul, Minnesota. By 1840, there was heavy river commerce between St. Louis and the head of navigation at St. Anthony's Falls located near St. Paul.

The Grand Excursion

In 1854, the Chicago and Rock Island Railroad became the first to reach the Mississippi River from the East Coast. To celebrate the event, people traveled from Chicago to Rock Island, Illinois, by train, and then traveled upriver to St. Paul, Minnesota, by steamboat.

Full steam ahead

Traffic on the Mississippi River was dominated by steamboats for most of the 19th and early 20th centuries. The period between 1830 and 1850 was the golden age of steamboats. Steam power made it quicker and cheaper to



Designed for both sea and river navigation, *Maid of Orleans* was the first steamboat to reach St. Louis from an Atlantic port in 1820. The note on the drawing reads, "Steamboat Maid of Orleans on the Mississippi River going to St. Louis."



The steamboat *War Eagle* operated between Galena, Illinois, and St. Paul, Minnesota. It was later rebuilt as the *Cape Girardeau*.

ship people and cargo, such as cotton, timber, coal, and produce, by river through New Orleans than to move them by land over the Appalachian Mountains. Because produce and products could be more easily transported to market, steamboats sparked the rapid growth of port cities, farming, trade, and prosperity along the river.

End of an era

The golden era of steamboats on the Mississippi River continued until the 1870s, when railroads began to surpass the river as the major commercial transportation mode for the central United States.

In 1856, the first railroad bridge was built across the Mississippi River between Davenport, Iowa, and the Rock Island

Fast Facts

- ◆ The first bridge across the Mississippi River was built in Minneapolis, Minnesota, in 1855.
- ◆ Steamboats did not always have steam whistles. Before steam whistles, bells had been used for passing signals and other communication between boats.



Steam boat bell from the *Belle of Louisville*

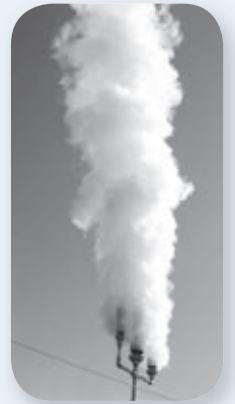

Steam whistle



The steamboat *Golden Era* operated on the Upper Mississippi and Red Rivers from 1852 to 1868 and saw service during the Civil War.

Lesson 4.2

The *Robert E. Lee*, nicknamed the “Monarch of the Mississippi,” was a steamboat built in 1866. It beat the former record holder, the *Natchez*, in a famous 1870 steamboat race.

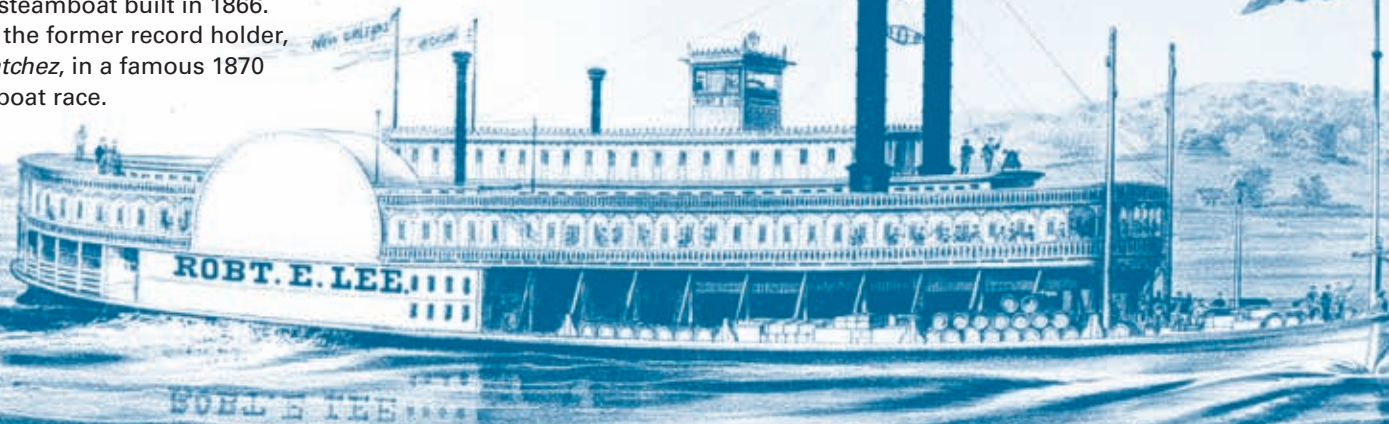

Arsenal in Illinois. Two weeks after it was completed, the steamboat *Effie Afton* hit the bridge and set it afire. Steamboat captains declared the bridge a hazard. In the lawsuit that followed, Abraham Lincoln defended the railroad and won.

Steamboat transport remained a viable industry, in terms of both passengers and freight, until about 1920.

Sources: U.S. Army Corps of Engineers; Library of Congress; Augustana College; Upper Mississippi River History; www.steamboats.org



Cover of the original U.S. edition, 1883.

“Ship channels are buoyed and lighted, and therefore it is a comparatively easy undertaking to learn to run them; clear-water rivers, with gravel bottoms, change their channels very gradually, and therefore one needs to learn them but once; but piloting becomes another matter when you apply it to vast streams like the Mississippi and the Missouri, whose alluvial banks cave and change constantly, whose snags are always hunting up new quarters, whose sand-bars are never at rest, whose channels are forever dodging and shirking, and whose obstructions must be confronted in all nights and all weathers without the aid of a single lighthouse or a single buoy; for there is neither light nor buoy to be found anywhere in all this three or four thousand miles of villainous river.”

—Mark Twain, *Life on the Mississippi*

James Watt

Inventor of the steam engine

James Watt (1736 – 1819) was a Scottish inventor and engineer who redesigned the steam engine and helped usher in the Industrial Age.

Legend says that Watt got the idea for his steam engine when he saw steam pressure lift the kettle lid. Although steam power was already in use before Watt's time, he took the idea and improved it, making it available on a major scale.

In 1755, Watt took out a patent on his design. For the next 55 years, the Boulton & Watt Company had a monopoly over the production of steam engines. Watt calculated the power exerted by a horse and described his machines in comparison to a horse, so he also invented the term "horsepower."

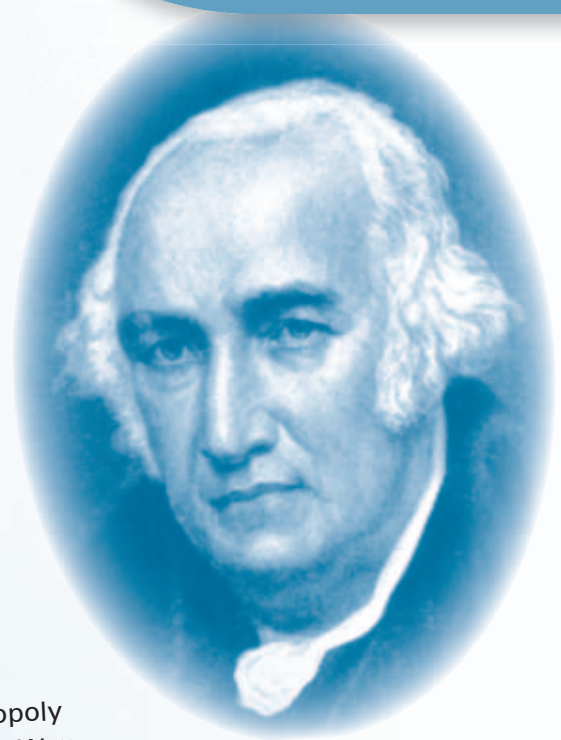

John Fitch

Inventor of the steamboat

John Fitch (1743 – 1798) was an American inventor, clockmaker, and silversmith born in Windsor, Connecticut. He built the first recorded steam-powered boat in the United States in 1787.

Fitch began working on ideas for a steam-powered boat in 1785, 30 years after Watt's patent. The first successful trial run of his steamboat was made on the Delaware River in 1787. In 1790, he launched another boat powered by several stern-mounted oars.

Fitch was granted a patent on August 26, 1791, after a battle with James Rumsey, who also invented a steam-powered boat. Fitch's legal dispute with Rumsey and others helped bring about the enactment of the first Patent Act in 1790.

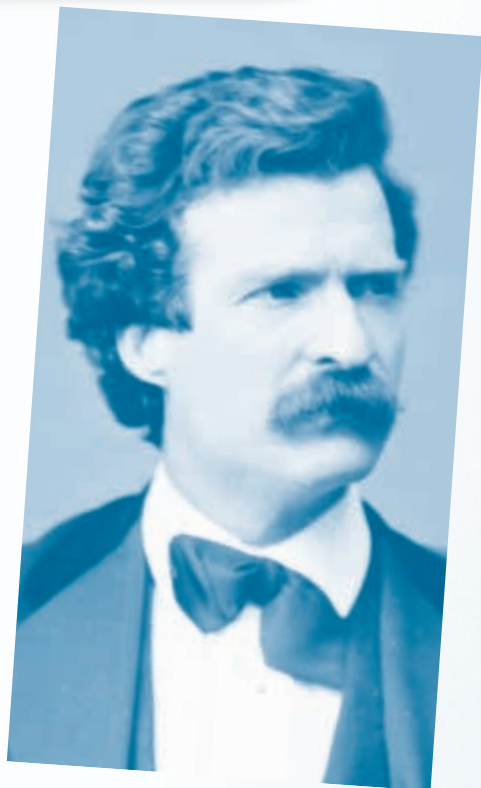

Samuel Clemens

Author and steamboat captain

Samuel Langhorne Clemens (1835 – 1910) was an American author and humorist. His pen name was Mark Twain. He is best known for his novel, *Adventures of Huckleberry Finn* (1884), which has been called “the Great American Novel.” Author William Faulkner called him the Father of American Literature.

Born in Missouri, he grew up in the port town of Hannibal on the Mississippi River. In 1859, at the age of 24, he realized a boyhood dream by becoming a steamboat pilot after serving as a cub pilot for two years under the tutelage of steamboat pilot Horace E. Bixby. Clemens chronicled his steamboat training and career in his book, *Life on the Mississippi*, written in 1883.

Blanche Leathers

First female steamboat captain

Blanche Douglass Leathers (1860 – 1940) was the first woman steamboat captain on the Mississippi River in the late 19th and early 20th centuries. Nicknamed “Angel of the Mississippi,” she had wanted to captain a steamboat since she was a little girl. She married into the Leathers family, a prominent steamboat family from New Orleans. Seven of the *Natchez* steamboats were built for the Leathers family. She and her husband, Bowling S. Leathers, both piloted the steamboat *Natchez VII*. Her father-in-law Captain T. P. Leathers commanded the *Natchez* in its historic 1870 race with the *Robert E. Lee* from New Orleans to St. Louis.



Who's Who on a Steamboat?

- **Captain:** Often the owner, the captain was in command of the steamboat. The captain was sometimes called the master.
- **Pilot:** The pilot steered the boat from the pilothouse on the top of the boat. Since there were no markers or buoys to operate by, pilots had to navigate the river largely from memory. An apprentice pilot was called a cub pilot.
- **Engineer:** The engineer started and stopped the boat's engines. Maintaining the appropriate water levels and steam pressure was very important because any sudden increase in pressure could lead to a catastrophic explosion.
- **First mate:** The first mate directed the handling of cargo and fuel, helped with landing and launching, and supervised the work of the deckhands.
- **Fireman:** Steamboats need a fireman to make sure there is enough fire to heat the water in the boilers to make steam and turn the paddlewheels.
- **Deckhands:** Also called stevedores or roustabouts, deckhands handled the freight and supplies carried aboard steamers. They also maintained and repaired the boat.

Discussion (60-90 minutes)

Show students scene 3, "The River Network Tamed," from the video *Confluence: The River Heritage of St. Louis* and a three-minute video clip on the history of the steam engine online at the History Channel's website. Go to www.history.com and search keywords **Modern Marvels Steam Engines Drive a Revolution**.

Remind students they learned about the types of boats that were powered by people (paddling, oaring, poling,

pulling) in the last lesson. Help students see the similarities and differences between paddling a canoe and a steam-powered paddle wheel.

Introduce the students to the inventors of the steamboat: John Fitch made the first successful trial of a steamboat, and Robert Fulton made further innovations and invented the first successful commercial steamboat, the *Clermont*. Discuss the impact of the steamboat on trade, migration, settlements, and transport.

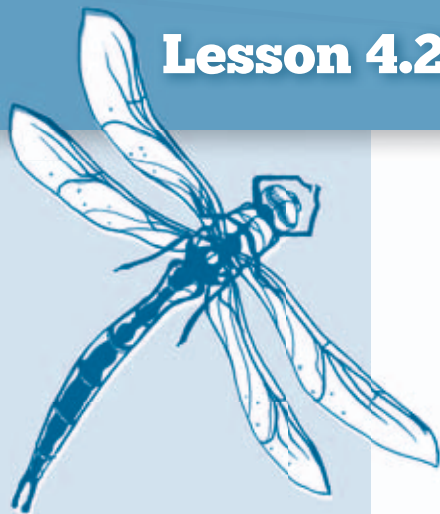

Grades
5-6

Teacher-led activity

30 MINUTES

Include time for water to boil

What you'll need

- 2 cups of water
- Toy pinwheel
- Hotpot or pot of boiling water
- Pot-holder glove



This activity can be a class demonstration or a group activity. If students are going to do this activity on their own, be sure to supervise them closely and remind them that steam can burn.

Create Your Own Steam Power

Steam is either mist (as seen from a kettle), or the gas phase of water (water vapor). Steam engines use the expansion of steam to drive a piston or turbine to perform mechanical work.

The steam engine is a heat engine. Heat energy from fuel is transferred to water in a boiler, making steam. Steam pressure is then converted to mechanical energy. Steam engines are classified as external combustion engines, because the fuel is burned under a boiler, and not inside the engine itself, as in gasoline and diesel engines.

Get Ready

1. Review the properties of water with students from lesson 1.3 in Unit 1.
2. Remind students that energy can change from one form to another.
3. Ask students to think about steam and explain the basic science of a steam engine.
 - Steam is the vapor state of water. The heat from burning fuel is absorbed by the liquid molecules in the water, exciting them. The water molecules begin to move faster and “break away” from the liquid surface, creating steam.
 - Like wind, steam has pressure. When it hits something, it can make it move, similar to how wind can turn a propeller. Pressure from the steam is used to create mechanical energy.

The Science of Steam Power

A steamboat is a ship that is powered by steam, which drives its paddlewheels. Steamboats with a paddlewheel mounted on the rear were called sternwheelers; those with paddlewheels on each side were side-wheelers.

A fire beneath the boilers in the engine room created enough heat to produce hot steam. The engine transformed the steam pressure to paddlewheel rotation. The higher the pressure, the faster the boat. Steamboats needed anywhere from 15 to 75

cords of wood a day – enough to build 15 houses – in the 1880s. People cut down the forests along the river's edge to power the steamboats until the supply was gone. Later steamboats were powered with coal.

Steam power could be dangerous because the high pressure could cause the boilers to burst. Many steamboats were destroyed and their passengers killed when their boilers exploded. If a boat was at a landing near a city or town when it happened, the explosion could also start a fire on land.

Sources: U.S. Army Corps of Engineers. Library of Congress; www.steamboats.com

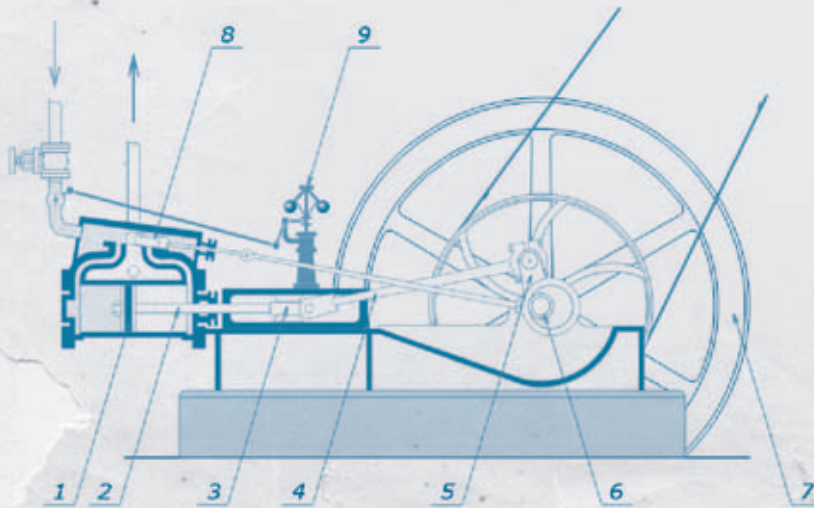

- 1 - Piston
- 2 - Piston rod
- 3 - Crosshead bearing
- 4 - Connecting rod
- 5 - Crank
- 6 - Eccentric valve motion
- 7 - Flywheel
- 8 - Sliding valve
- 9 - Centrifugal governor

Do This

1. Put the water in the pot and bring it to a boil.
2. Wearing an oven mitt or protective glove, hold a toy pinwheel over the steam of the boiling water.
3. Observe what happens to the pinwheel.
4. Move the pinwheel away from the steam and see what happens.
5. Ask students to explain in writing what happened.

What Should Happen

The heated water molecules from the steam move faster and farther apart. The steam becomes lighter and rises upward, creating an air current which moves the pinwheel.

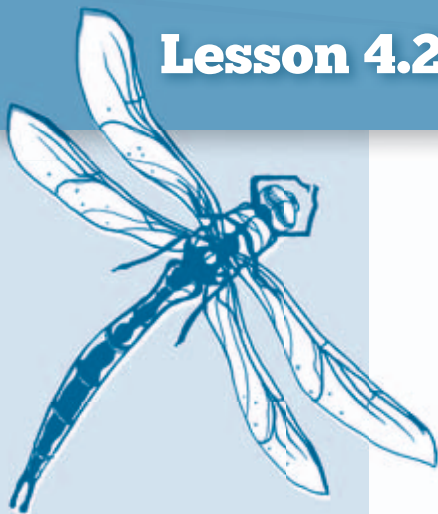

Marking the Twain

Grades

5-6

Individual activity

1 HOUR

What you'll need

- Activity worksheet and map (pages 246–247)
- Cub pilot journal

Samuel Clemens (Mark Twain) received good advice from Horace Bixby, the river pilot who taught him how to read the river. The notebook Clemens used was ruled for use as a ledger and contains the cargo records of a steamboat clerk, suggesting that Clemens probably acquired it in some haste from that clerk. The dense texture of navigational directions on the pages displayed includes the young pilot's notes in the area of St. Louis.

When Clemens was learning how to pilot a steamboat, there were no buoys to guide him or locks and dams to help him navigate the changes in depth. He needed to know a hundred landmarks for every mile of the journey so he could know the shape of the river at night. Every point, stump, limb, ridge, rock, or snag had told him something about the river. He had to steer for the slack water, staying close first to one bank and then the other. To find slack water, he had to know the shape of the river so well he did not actually need to see the landmarks.

He also had to know the depth of the river in all places.

This depth was measured by the pilot's leadsmen who constantly monitored the amount of water under the bow and stern of the boat.

Get Ready

1. Read the quote attributed to Horace Bixby in *Life on the Mississippi* (on next page) and ask students to imagine the skills and knowledge required to be a steamboat pilot. Think about how writing things down helps you remember them.



“My boy, you must get a little memorandum-book, and every time I tell you a thing, put it down right away. There's only one way to be a pilot, and that is to get this entire river by heart. You have to know it just like A B C.”

—Horace Bixby, from Mark Twain's *Life on the Mississippi*



2. Explain how pilots “read the river,” a term used to describe the way pilots memorized the river’s landmarks and characteristics and constantly monitored its current conditions.

- Reading a constantly changing river meant understanding – and being on the lookout for – where the river was building sandbars by depositing silt and where it was moving obstructions such as logs or snags.
- Pilots had to constantly monitor water levels and know where the water was deep enough to navigate.
- They also had to know an area well enough to steer around, over, or through obstacles or hazards such as bridges and submerged rocks or other objects in any weather, day or night.

3. Explain how Samuel Clemens chose the pen name Mark Twain and what it means to “mark the twain.”

Do This

1. Ask students to “mark the twain” on the map on page 247. The activity worksheet on page 246 explains the term and how it was used.
2. Using the twain measurements in the activity worksheet, they should note by highlighting or circling which areas on the map are above twain and below twain.
3. Ask students to also star any numbers that represent “mark twain” (safe water) or “no bottom.”
4. Ask students to describe what it would be like to navigate this part of the river in their “cub pilot” journal.



Answer key for activity worksheets (page 246–247): Students should find at least one example of each measurement listed on the activity worksheet on page 246. They should also star all measurements of 12 feet or more as representing safe water.



Marking the Twain

Name _____ Date _____



*Quarter less twain
 Quarter less twain
 Lawd, Lawd, no send me quarter less twain
 Throw the lead line a little higher out.
 I've gone low down, so mark twain,
 Mark twain.
 Come ahead, Mr. Pilot, a little bit strong.
 I've done got over, and I believe we're gonna
 Throw the leadline over—
 No bottom here.*

– from *Work Songs* by Ted Gioia

“MarkTwain,” the pen name of American author Samuel Clemens, was the call the leadman made when the boat was in safe water. It meant the water was two fathoms (12 feet) deep.

A fathom was a unit of measurement the length of a man’s outstretched arms (approximately 6 feet). Twain is an archaic term for the number two, so MarkTwain means “mark two.”

A leadman determined the depth of the river using a leadline, which was a 30-foot-long weighted rope with incremental distances marked on it. He shouted these measurements to the pilot:

“Quarter”	1-1/2 feet (one quarter of a twain)
“Half”	3 feet (1/4 twain)
“Quarter Less”	4.5 feet (twain minus 1-1/2 feet)
“Mark One”	6 feet (1/2 twain)
“Quarter One”	7-1/2 feet
“Half One”	9 feet
“Quarter Less Twain”	10-1/2 feet
“Mark Twain” (safe water)	12 feet
“Quarter Twain”	13-1/2 feet
“Half Twain”	15 feet
“Quarter Less Three”	16-1/2
“Mark Three”	18 feet
“Quarter Three”	19-1/2 feet
“Half Three”	21 feet
“Quarter Less Four”	22-1/2 feet
“Mark Four”	24 feet
“No Bottom”	Any depth over 24 feet

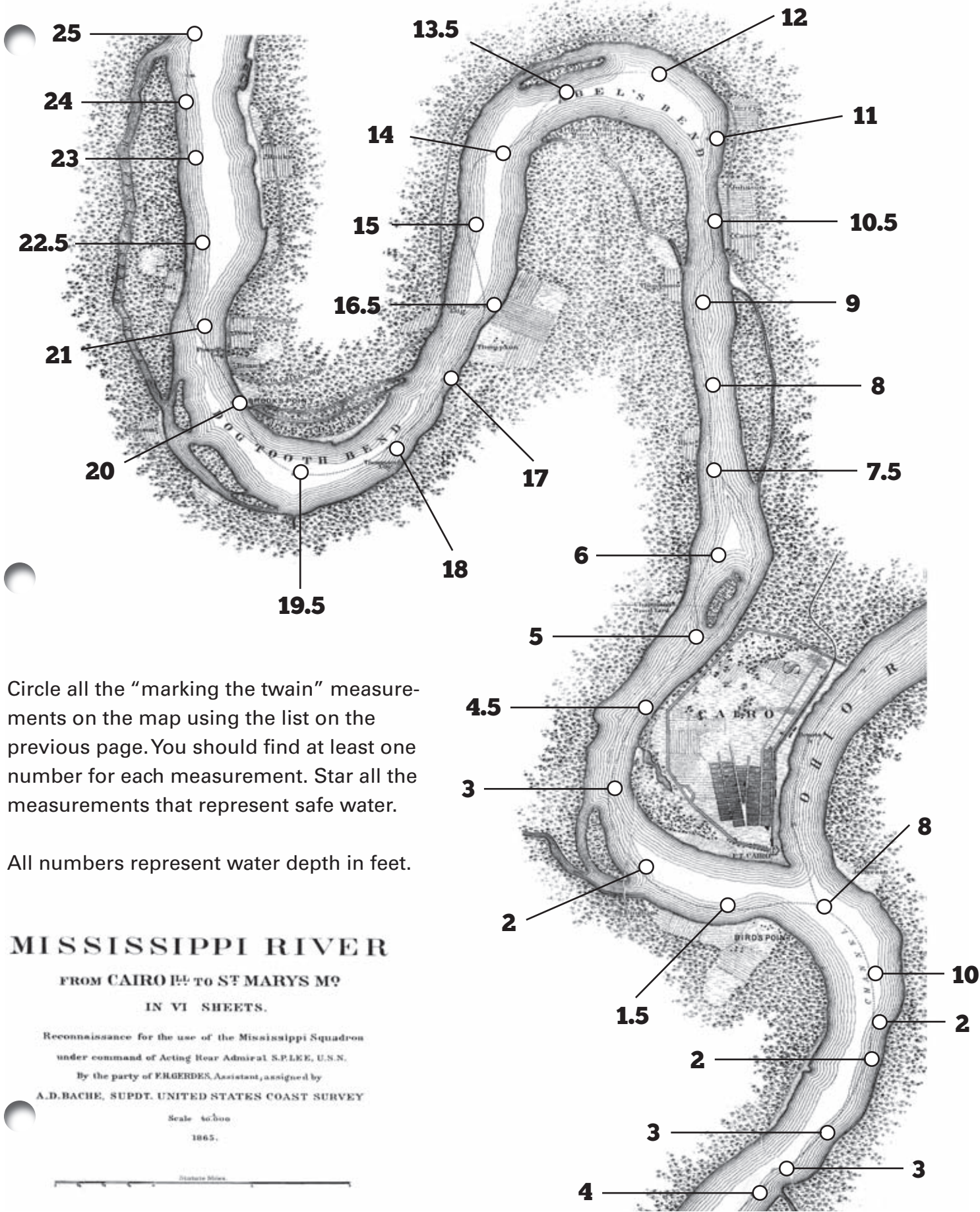

Circle all the "marking the twain" measurements on the map using the list on the previous page. You should find at least one number for each measurement. Star all the measurements that represent safe water.

All numbers represent water depth in feet.

MISSISSIPPI RIVER
 FROM CAIRO ILL. TO ST. MARYS MO.
 IN VI SHEETS.
 Reconnaissance for the use of the Mississippi Squadron
 under command of Acting Rear Admiral S. P. LEE, U.S.N.
 By the party of F. H. GERDES, Assistant, assigned by
 A. D. BACHE, SUPDT. UNITED STATES COAST SURVEY
 Scale 40,000
 1865.
 Statute Miles

Lesson 4.2

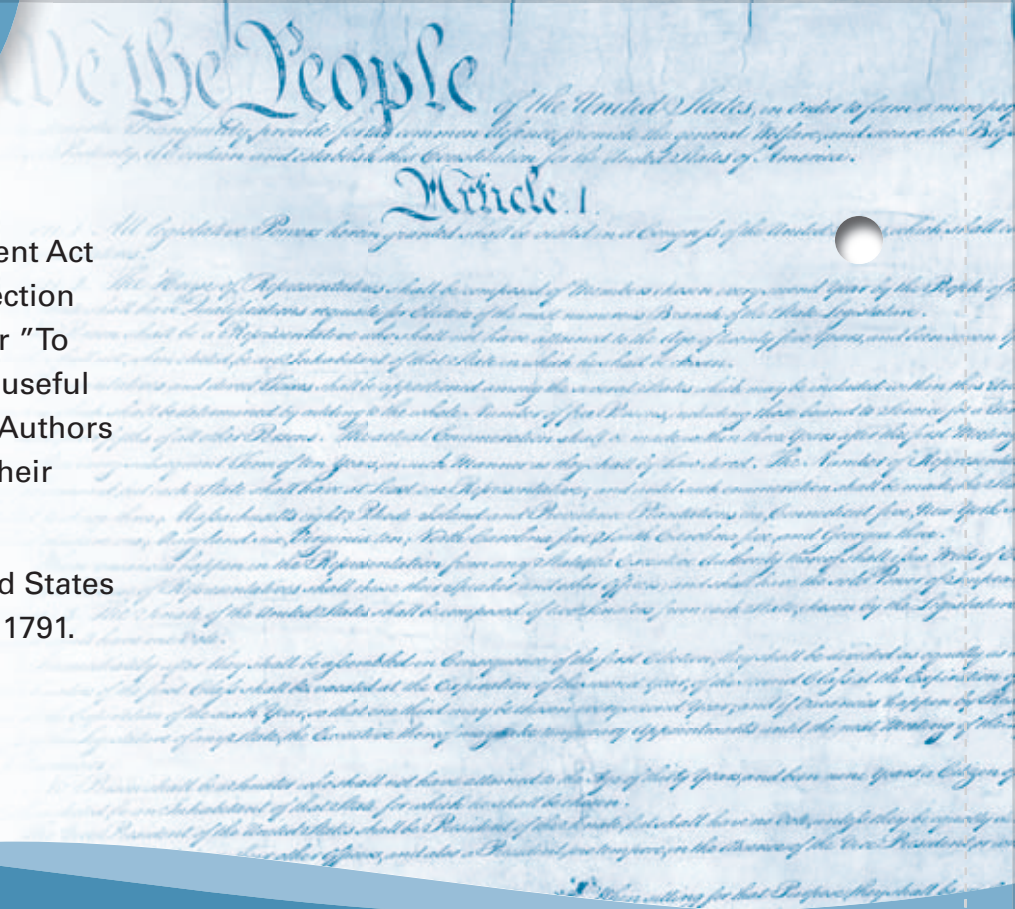

Congress passed the first Federal Patent Act in 1790. The Constitution (Article 1, Section 8, Clause 8) gives Congress the power "To promote the Progress of Science and useful Arts, by securing for limited Times to Authors and Inventors the exclusive Right to their respective Writings and Discoveries."

John Fitch was granted his first United States patent for a steamboat on August 26, 1791.

Extension Suggestions



~ Career launch

Invite a local **captain** or **pilot** to speak to the class. Ask students to research the field and prepare questions in advance. See *A1: Career Launch* on page 312 for career information and professional associations.

~ Get out!

Go ride on a steamboat and keep a log of the journey.

~ Express yourself!

- Write a song about steamboats.
- Draw a steamboat.
- Write a play about working on a steamboat using as many steamboat terms as possible.

~ Read about it

Read "Cooling Our Bottom on The Sand Bars": A Chronicle of a Low Water Trip by Michael H. Marleau. This feature compares Samuel Clemens' journals with a letter to the *St. Louis Missouri Republican* believed to be written by Clemens. Ask students to read the letter and decide if they agree. Go to www.twainquotes.com and search for "cooling our bottom."

Welcome to Our Mississippi

File Edit View Favorites Tools Help



http://www.OurMississippi.org

~ Learn more online

Explore an interactive steamboat model online at www.steamboats.org

Click button: **History and Education**

Search keywords: **Interactive steamboat model**

Learn more about U.S. Patents from the **United States Patent and Trademark Office's** website www.uspto.gov.

Search keywords: **USPTO for kids**

Find steamboat news stories and pictures of past and present steamboats at www.steamboats.org

Download the works of Mark Twain at **Project Gutenberg**. Go to www.gutenberg.org and search keywords: **Mark Twain**

River Running Dry, River Running High

Major Floods on the Upper Mississippi River

Introduction

In *Lesson 4.3*, students learn about the changeable nature of the Upper Mississippi River and how it alternates between flooding and drought.

STANDARDS CORRELATION

This lesson combines history, social science, and language arts standards to help students understand the impact floods have on the lives of people. Students learn about the 1927 and the 1993 Mississippi River floods through multimedia sources, including documentaries, raw footage, amateur video, and newscasts. They use the knowledge and insight gained from studying these disasters to write their own newscasts to inform their communities about what causes floods and what they can do to protect themselves during the ups and downs of the Upper Mississippi River.



~ Unit 4 goal reminder

Explore the Mississippi River at work and how it has changed over time

~ Lesson goal

Understand the natural cycles of flooding and drought on the Upper Mississippi River

~ Lesson objectives

- Discuss causes of flooding
- Identify major floods along the Mississippi River
- Research what kind of technology was used after each major flood
- Produce news article and broadcast

~ Educational standards

- Science
- Social Studies
- Fine Arts
- Language Arts

~ What you'll need

- U.S. Army Signal Corps historic footage of the 1927 flood
- PBS Nova online video *The Great Flood of 1993*
- Guest speaker
- Student journals
- Library and Internet access
- Digital video recorder
- Computer with DVD player and video editing software, such as iMovie

~ How long it will take

- Several one-hour sessions for students to research, prepare, and conduct the interviews
- Actual broadcast can be 15-30 minutes

~ What's next!

How locks and dams made the Upper Mississippi River the ultimate travel corridor

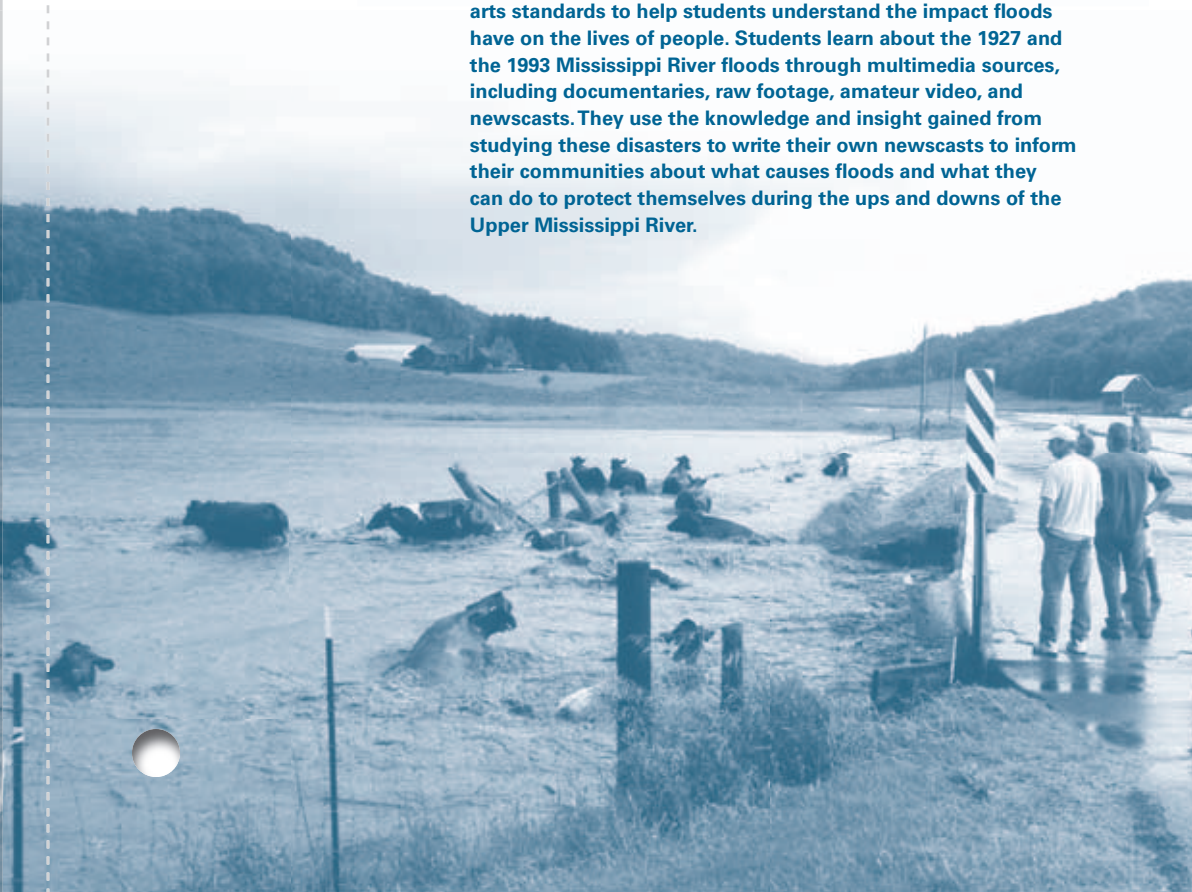

Background

Free-flowing river

People living along the Mississippi River were well aware of the flooding potential of the Mississippi River. Native American settlements were located on higher land. Hernando de Soto, the first European to explore the Mississippi, noticed how much the river flooded.

In its natural state, the Upper Mississippi River experienced cycles of high and low water levels. In wet years, river

levels were high and turbulent. In dry years, water levels lowered to a trickle in some places. The plants and animals that lived along the Upper Mississippi River adapted to the river's larger range of water level fluctuations. In fact, they depended on these fluctuations. Steamboats, however, were not so adaptable. High, fast waters were difficult to navigate. During a drought, water levels were too low for navigation, and many steamboats became stranded on sandbars.

Major Floods on the Mississippi River

The history of the Mississippi River is one of frequent floods.



1927

The Great Mississippi Flood of 1927 was one of the most destructive floods in the history of the United States. The river crested at 56.60 feet at Natchez, Mississippi, on May 4, 1927, 8.60 feet above flood stage.



1965

The river crested at 24.85 feet in Clinton, Iowa, on April 28.

The young city of New Orleans near the mouth of the Mississippi began to build levees four to six feet in height to protect itself from floods. By 1812 levees had been built to protect land for more than 150 miles north of New Orleans.

Environmental impact of steamboats

Steamboat traffic had severe adverse environmental effects on the Mississippi River, especially between St. Louis and the confluence with the Ohio River.

Steamboats needed anywhere from 15 to 75 cords of wood a day, enough to build 15 houses in the 1880s. The steamboats consumed so much wood for fuel that the Mississippi River's floodplain soon became deforested. Without forests to anchor the soil, more sediment was released into the river. The Mississippi River became both wider and more shallow, making navigation more difficult and dangerous.



1993

The river crested at 49.47 feet in St. Louis, Missouri, 19 feet above flood stage.



2001

River crested at nearly 16.41 feet, in La Crosse, Wisconsin, four feet above flood stage.



2008

The river crested at 36.70 ft at Clarksville Lock and Dam in Missouri, 11.70 feet above flood stage on June 24, 2008.

Lesson 4.3



UNIT 4

Containing the river

By the late 1800s, the importance of the Mississippi River as a transportation corridor was well established. Congress wanted to protect this vital resource, so they passed legislation to improve the river for navigation and protect communities against flooding. In 1879 Congress established the Mississippi River Commission to work with the U.S. Army Corps of Engineers to prevent destructive floods and deepen the river channel to make navigation safer and easier.

In 1917, Congress passed the country's first flood control act, authorizing the U.S. Army Corps of Engineers to work on levees from Illinois to Louisiana. By 1926, the Corps finished the construction of levees stretching from Cairo, Illinois to New Orleans, Louisiana.

Great Flood of 1927

The Great Mississippi Flood of 1927 was one of the most destructive floods in the history of the United States. In the summer and fall of 1926, violent storms dumped ten times the yearly average rainfall into tributaries throughout the Mississippi River watershed. On April 16 a 1,200-foot length of levee collapsed near Greenville, Mississippi, breaking with a force double that of Niagara Falls. It flooded an area 50 miles wide and more than 100 miles long, killing 246 people in seven states and causing over \$400 million in damage.

Aerial view below shows the levee break at Mounds Landing, Mississippi, during the flood of 1927.

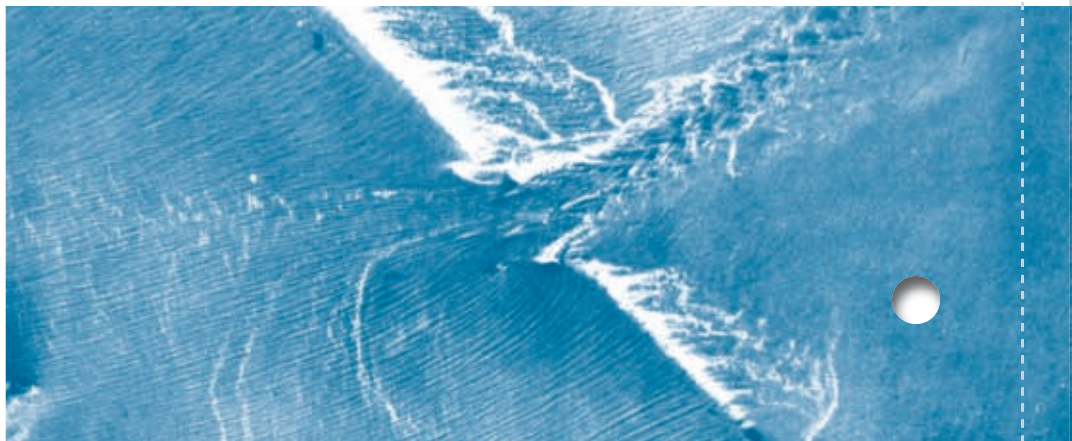

Map of the flood of 1927

In response to the devastating flood of 1927, Congress passed the 1928 Flood Control Act authorizing the U.S. Army Corps of Engineers to design and construct projects for the control of floods on the Mississippi River and its tributaries.

Great Flood of 1993

In 1993 another disastrous Mississippi River flood hit the Midwest, rivaling the devastation of the 1927 flood. Record precipitation again fell on the Mississippi watershed, starting in the fall of 1992, continuing as snow during the winter, followed by heavy spring rains.

From May through September of 1993, major flooding occurred across North Dakota, South Dakota, Nebraska, Kansas, Minnesota, Iowa, Missouri, Wisconsin, and Illinois. Near-record flows on the Mississippi River pushed the stage at St. Louis up to a new record high of 47 feet on July 20. Less than two weeks later, the river set another record crest of 49.47 feet at St. Louis on August 1.

In all, 92 locations set new record crests in 1993. Damage totaled \$15 billion, 50 people died, hundreds of levees failed, and thousands of people were displaced for months.

Sources: U.S. Army Corps of Engineers, NOAA (National Oceanic and Atmospheric Administration), NASA (National Aeronautics and Space Administration).

These two photos below compare the Mississippi River near St. Louis before and during the Great Flood of 1993. The photo on the left is from August 1991. The photo on the right is from August 1993, just after floodwaters had started to recede after the Flood of 1993.

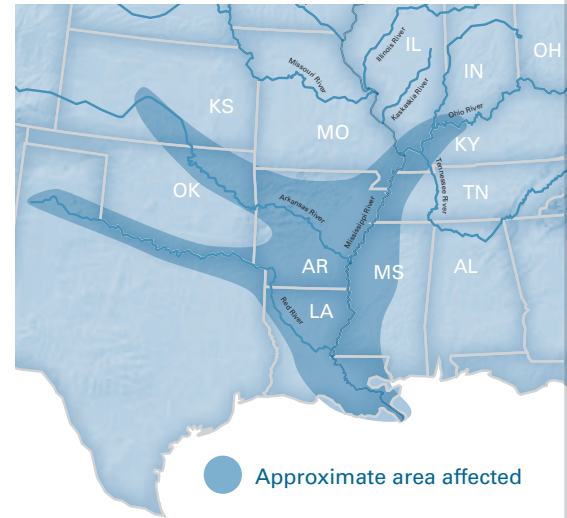

Extent of flooding in 1927

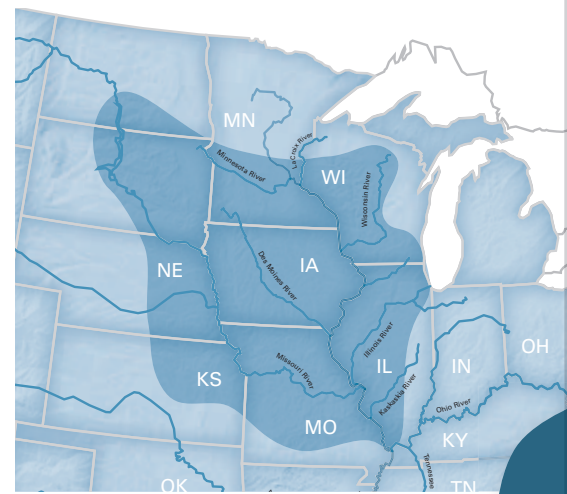

Extent of flooding in 1993

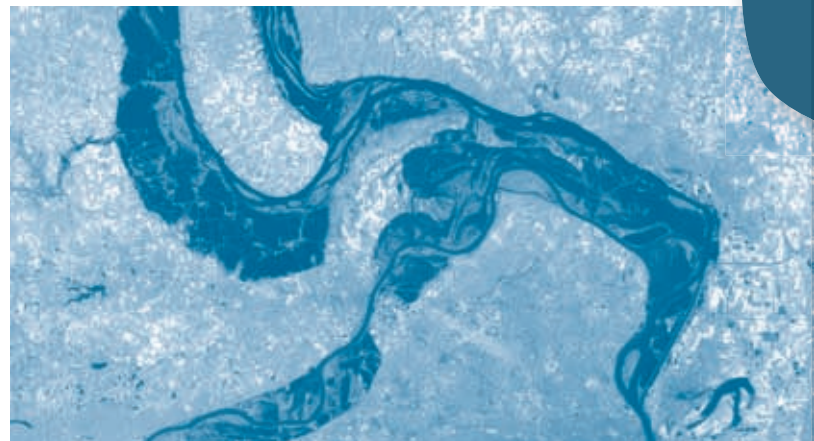
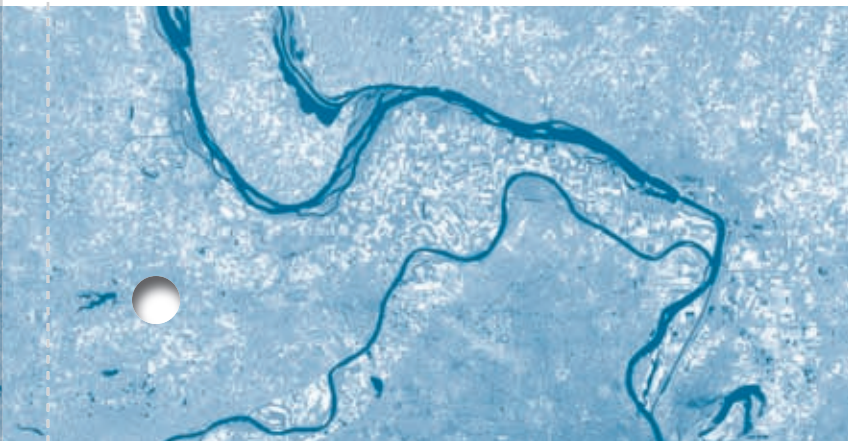

Lesson 4.3

Need to Know

- **Weather:** The day-to-day state of the atmosphere, and its short-term (minutes to weeks) variation. Popularly, weather is thought of as the combination of temperature, humidity, precipitation, cloudiness, visibility, and wind.
- **Climate:** Statistical weather information that describes the variation of weather at a given place for a specified interval. It represents the synthesis of weather; more formally it is the weather of a locality averaged over some period (usually 30 years) plus statistics of weather extremes.
- **Crest:** A high point of an action or process.
- **Floodplain:** A flat or nearly flat land next to a stream or river that occasionally or periodically floods.
- **Flood stage:** An established gage height for a given location above which a rise in water surface level begins to create a hazard to lives, property, or commerce.

Discussion (60 minutes)

Review key terms and concepts from *Lesson 1.3 Going with the Flow: The Ups and Downs of the Water Cycle* and introduce major Upper Mississippi River floods. Discuss them in the context of the river’s natural cycle of droughts and floods and explain how climate and seasonal weather patterns impact the river. Have students watch the videos and write in their journals about their emotional reaction to the stories.

You’ll need

- *Mississippi River Flood of 1927*, an 18-minute silent film of the actual flood. Available free for downloading in several formats and for viewing online at Internet Archive (registration required). Go to www.archive.org. After registering, search for “Mississippi River Flood of 1927”
- PBS Nova 5-minute video *The Great Flood of 1993*. Available free as a quicktime file at <http://www.teachersdomain.org> (registration required)
- Student journals

Synopsis for *Mississippi River Flood of 1927:* (Rare, archival footage of the 1927 Mississippi River flood produced by the U.S. Army Signal Corps)

This silent film captures one of the most dangerous floods in U.S. history in its historical context. Title cards interpret footage from Illinois, Mississippi, and Louisiana. Clips include floodwaters carrying houses and debris, marooned families and their livestock, levees being reinforced, biplanes searching for survivors, steamboats

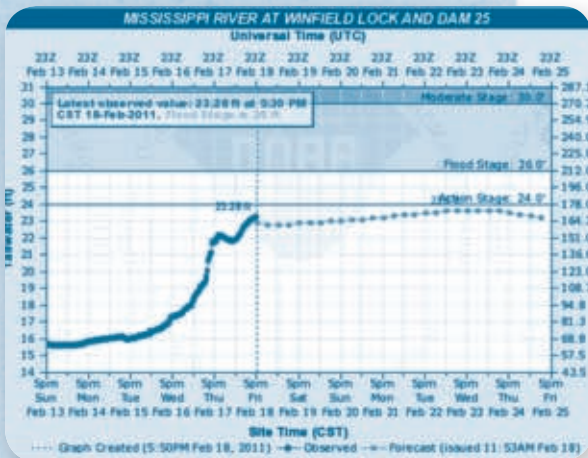

rescuing stranded residents, and Secretary of Commerce Herbert Hoover meeting with Red Cross officials.

Synopsis for *The Great Flood of 1993*

During a typical year, levees built along the banks of the Mississippi River keep the river in its channel and out of people's homes and fields. However, 1993 was anything but a typical summer. This video segment adapted from *NOVA* describes the meteorological conditions that created what was then the costliest flood in United States history.

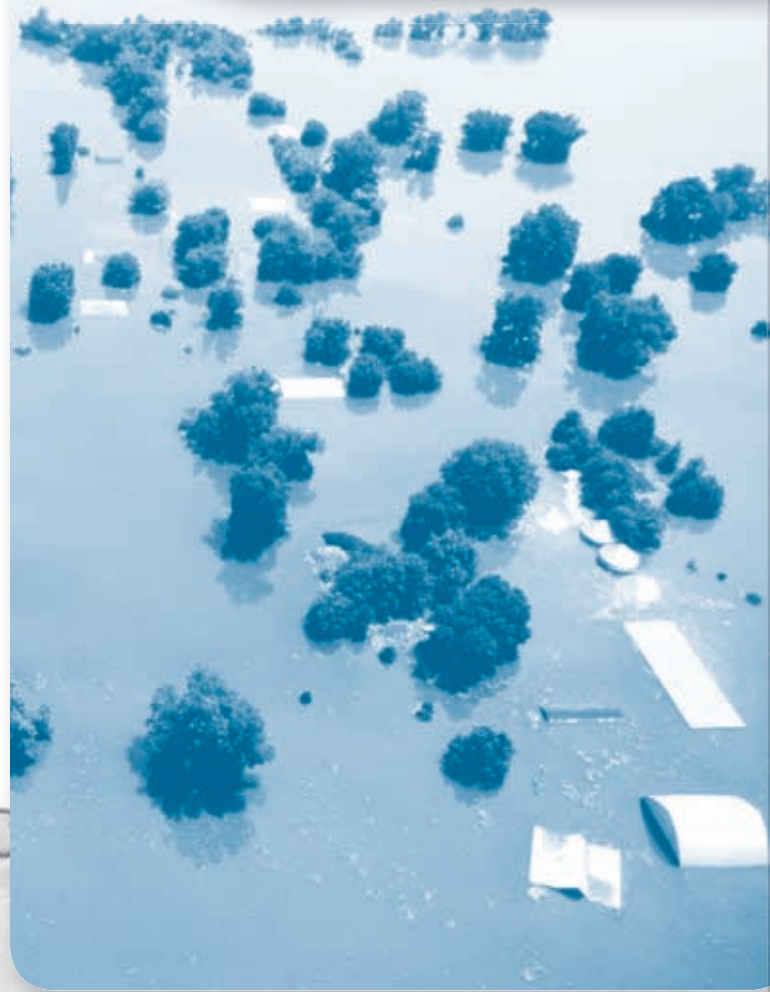

When the Levee Breaks...

When the Levee Breaks is a Delta blues song written and first recorded by husband and wife Kansas Joe McCoy and Memphis Minnie in 1929. The song is in reaction to the upheaval caused by the Great Mississippi Flood of 1927.

If it keeps on rainin',
levee's goin' to break
And the water gonna come in,
have no place to stay

Well all last night
I sat on the levee and moan
Thinkin' 'bout my baby
and my happy home

If it keeps on rainin',
levee's goin' to break
And all these people
have no place to stay

Now look here mama
what am I to do
I ain't got nobody
to tell my troubles to

I works on the levee mama
both night and day
I ain't got nobody,
keep the water away

Oh cryin' won't help you,
prayin' won't do no good
When the levee breaks,
mama, you got to lose

I works on the levee,
mama both night and day
I works so hard,
to keep the water away

I had a woman,
she wouldn't do for me
I'm goin' back
to my used to be

It's a mean old levee,
cause me to weep and moan
Gonna leave my baby,
and my happy home

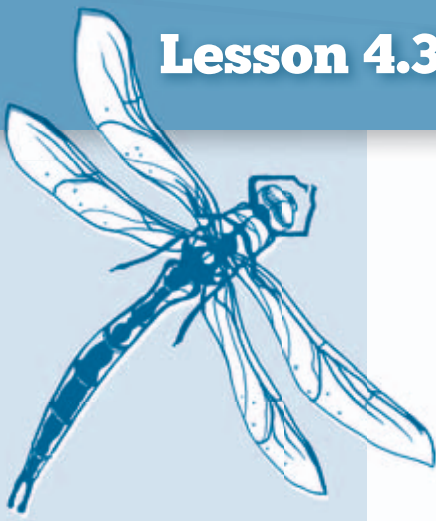

Grades
5-6

Group activity

1/2 DAY

- Several one-hour sessions for students to research, prepare, conduct interviews, write and edit material as a group
- Actual broadcast can be 10-15 minutes for each group)

What You'll Need

- A guest speaker
- Library and Internet access
- Audiovisual script activity worksheet (pages 258–259)
- Digital video recorder
- Computer with DVD player and video editing software, such as iMovie

Breaking News!

River Reports

Ask students to work in teams to plan and produce a 10 to 15 minute broadcast news story about how their community prepared for—or recovered from—a recent flood.

Get Ready

1. Ask students to think about what they learned about Mississippi River floods from the videos and class discussions. Ask them if they had any questions about the floods that were not addressed.
2. Introduce the audiovisual script activity worksheet and explain that multimedia stories are planned and written in columns (one for visuals and one for the script)
3. Have students search www.youtube.com for past news coverage and raw footage of floods.
 - Suggest using search terms that include “Mississippi River flood” (in quotes) with the dates of major floods (1993, 2001, 2008).
 - Ask them to critically evaluate their sources for accuracy and credibility.
4. Invite a local reporter to talk to the class as part of their preparation.



If you lack resources to create a multimedia broadcast, such as a digital video recorder and DVD player, adapt the activity for radio broadcast with sound effects, a PowerPoint presentation with visuals, or a print story with photos and diagrams. If these are not available, have students make a report to the class.

Do This

1. Organize students into “newsroom” groups and let them assign themselves roles: writers, reporters, and producers.
2. Ask students to determine their “angle” or research question they will use to narrow their focus and plan their research and interviews accordingly.
3. Have students research history of flooding in their area at the library and on the Internet and determine individuals to interview for their stories.
4. Have students write up their interviews and text for the news reporters.
5. Use the final script and their video for assessment.





Breaking News!

River Reports

Name _____ Date _____

Use your investigative and communication skills to report on the most recent flood in your area. Work with your group to plan and produce a 10 to 15 minute broadcast news story about a local flood.

What's the story?

Determine your story's purpose or "angle." What does your audience need to know about the most recent flood? Write it as a research question and use it to guide your research and interviews.

1. What is your research question / angle?

2. Narrow down your topic. What specifically will your story cover? _____

3. Write your audiovisual script in columns as shown in the sample. _____



Sample audiovisual script

Video	Audio
<p>Kids getting off the bus at a river restoration site.</p> <p>Close-up of student in tall boots holding a shovel in one gloved hand and a native plant in the other.</p> <p>Close-up of student planting a native plant.</p>	<p>Riverside Elementary school students are helping make the world a better place.</p> <p>After learning how the loss of wetlands increases the severity of floods, they decided to do something about it.</p>
<p>Wide shot of river showing birds, boats, and people on and along the river.</p> <p>Zoom in to a spot next to the river that is just bare rocks and dirt.</p> <p>Close-up of first student as she speaks.</p> <p>Wide shot of student's faces listening.</p>	<p>A long time ago this used to be a wetland full of lots of different kinds of plants and animals.</p> <p>Now, it's just a parking lot that few people use.</p> <p>Our class is going to help the city restore it by planting native plants.</p>
<p>Wide shot of City Parks Manager John Smith standing with the teacher Jane Doe and several students.</p> <p>Close-ups of John Smith and Jane Doe talking.</p>	<p>"The students are doing important work," says City Parks Manager John Smith. "Over time, this area will become a fully functional wetland. When the river floods, it will absorb some of the water, helping to prevent flooding downtown."</p> <p>"After learning about the importance of wetlands, the class wanted to find a project that would help restore one in their community," says Jane Doe.</p>

Lesson 4.3



Extension Suggestions



~ Career launch

Invite a local **news reporter** or **TV anchor** to speak to the class. Ask students to research

the field and prepare questions in advance. See *A1: Career Launch* on page 312 for career information and professional associations.

~ Express yourself!

- Write a news story for your school newspaper about the history of natural disasters in your area. Include information on disaster preparedness.
- Write a song about the 1927 or 1993 flood.

~ Get out!

- Interview people in your community about floods and other natural disasters.
- Hike along the Mississippi River and look for evidence of flooding.
- Prepare a flood preparedness plan for your school, neighborhood, or family.

~ Think about it

- Analyze the historic floods of the Mississippi River in the context of the massive floods that occurred during the Pleistocene. Help students find primary sources that describe the archeological evidence for Ice Age floods. *Review 1.1 Movers and Scrapers: Upper Mississippi Glaciations* for background information.

~ Compare and contrast

- Compare and contrast the 1927 Mississippi River Flood with the 1931 Yangtze River Flood in China.
- Compare and contrast the 1927 and the 1993 floods. Investigate the aftermath of the 1927 flood as a major factor of the Great Migration of African Americans to northern cities, using maps and timelines, and compare this migration to the Underground Railroad (see *Lesson 3.5 Mississippi River: Pathway to Freedom*). Note similarities and differences in the routes, destination, and reasons for migration.

Welcome to Our Mississippi

File Edit View Favorites Tools Help



http://www.OurMississippi.org

~ Learn more online

Learn about floods and floodplains from the **U.S. Geological Survey** (www.usgs.gov)

Search keywords: **floods and floodplains**

Revisit the history of the Mississippi River and Tributaries Project with the U.S. Army Corps of Engineers (www.mvn.usace.army.mil)

Search keywords: **Mississippi River and Tributaries Project**

Learn about the 1993 flood from **National Geographic** (www.nationalgeographic.com)
Search keywords: **1993 Mississippi River flood**

Review flood risk scenarios online and determine your own risk at **National Flood Insurance Program** website (www.floodsmart.gov)

See Flood Preparedness Plans at the **Federal Emergency Management Agency** (www.fema.gov/kids)

Explore interactive galleries and lessons about natural disasters at **National Geographic's Xpeditions** website. (www.nationalgeographic.com/xpeditions)

Search keywords: **Living Landscapes**

Learn more about the 1927 and 1993 floods from **PBS** (www.pbs.org)

Search keywords: **Mississippi River floods**

Controlling the River:

Locks and Dams on the Upper Mississippi River

Introduction

In *Lesson 4.4*, students learn how locks and dams make the Upper Mississippi River an important travel corridor. Students demonstrate how gravity raises or lowers water, which helps them understand how watercraft move from one lock to the next.

This lesson covers the history of the lock and dam system on the Upper Mississippi River, including why and how navigation is maintained on the river. Students understand why a clear channel is necessary to make the Upper Mississippi River a major transportation corridor.

STANDARDS CORRELATION

In this lesson, students study some of the pros and cons of taming the river, which relate to several social studies standards. The lesson also touches on physical science standards as students are challenged to create a working lock.



~ Unit 4 goal reminder

Explore the Mississippi River at work and how it has changed over time

~ Lesson goal

Learn how locks and dams make it possible to navigate the Upper Mississippi River

~ Lesson objectives

- Explore how locks and dams changed the river
- Discuss the impact on wildlife
- Watch how a lock works
- Build a lock system

~ Educational standards

- Science
- Social Studies
- Fine Arts
- Math
- Language Arts

~ What you'll need

- Grease pencil or permanent marker
- 2 half-gallon milk or juice cartons
- Plastic container (about 18" x 24" x 6")
- Modeling clay
- Ruler (with centimeters)
- Scissors
- Water to fill plastic container 3 cc deep
- Pencil and paper

~ How long it will take

- Preparation: 1 hour
- Student Activity: 2 hours

~ What's next!

Going to market up and down the river

Lesson 4.4

Background

The upper and lower Mississippi are very different rivers. On the Lower Mississippi River, there is no need for locks. Below the confluence of the Mississippi and Missouri Rivers, the Mississippi is deep enough and has minimal impediments for river travel, thanks to several major tributaries that feed into it.

Not so on the Upper Mississippi River. North of the Mississippi and Missouri confluence, numerous snags, sandbars, rapids, and other obstructions made river travel difficult. The waters of the Upper Mississippi River split and rejoined in countless side channels, producing a dynamic mosaic of islands, floodplains, wetlands, and river.

During the drought of 1864, the river was dry in so many places that there was no river traffic that year. It became clear if people were going to depend on the Upper Mississippi River for transportation and trade, a minimum level of depth needed to be maintained.

Based on gage data and engineering judgment, a low water mark was established. In 1878, Congress authorized the U.S. Army Corps of Engineers to establish a 4.5-foot deep channel. This eventually became the 9-foot channel we have today.

Early improvements of the Mississippi River above Cairo, Illinois, consisted mostly of removal of snags and closure of sloughs to confine low-water flows to



the main channel. Later, dredging and other channel improvements made the river navigable as far north as St. Paul and Minneapolis in Minnesota.

The Mississippi River became completely navigable from New Orleans to St. Paul with the opening of the Moline Lock that bypassed Illinois Rock Island Rapids in 1907.

In 1930, Congress authorized construction of a 9-foot channel between Minneapolis and the mouth of the Illinois River, just above St. Louis, providing for the construction of locks and dams. Dams were built on shallow rivers to hold back water and form deeper navigation pools with a constant minimum water depth of 9 feet in the

channel for safe navigation. These dams make it necessary for river vessels to use a series of locks to “step” up or down the river from one water level to another.

Construction of these structures occurred mostly in the 1930s and 1940s and resulted in a total of 29 locks and dams. This system created what is commonly called a “Stairway of Water” as the Mississippi falls 420 feet from the Falls of St. Anthony in Minnesota to Locks #27 in Granite City, Illinois. The dams create slack-water pools for navigation during periods of low and medium flows. The locks pass river traffic from one pool to another, like a stairway of water.

River Management Timeline

1830s

Federal government authorizes removal of snags, shoals, and sand bars. Backwater is closed to keep more water in the main channel and rocks are dynamited and excavated to remove the rapids and deepen the water.

1878

Congress authorizes the maintenance of a 4.5-foot-deep channel, and several locks are built to bypass rapids. Cities built on flood plains build levees for protection against flooding.

1907

Congress authorizes a 6-foot-deep channel. Wing dams are built. These are essentially low dikes made of rocks and brush that extend from the river bank toward the channel. They force water into the central channel, which scours the channel deeper.

1930

Congress authorizes a 9-foot-deep, 300-foot-wide channel to accommodate large towboats and barges. The construction of a system of 29 locks and dams created a “staircase” of deep-water pools that helps maintain consistent channel depth and allows tugboats and barges to travel safely up and down the river.

Lesson 4.4

Managing the Upper Mississippi River

A variety of different river management techniques are used for both navigation and flood risk management. Some of these are natural, including preserving or restoring natural areas that help maintain functioning ecosystems and the benefits they provide. Others are structural, such as the locks and dams built by the U.S. Army Corps of Engineers.

However, these structures come at an environmental cost. They interfere with natural river processes on the Upper Mississippi and Illinois Rivers, essentially changing free-flowing rivers into a string of reservoirs.

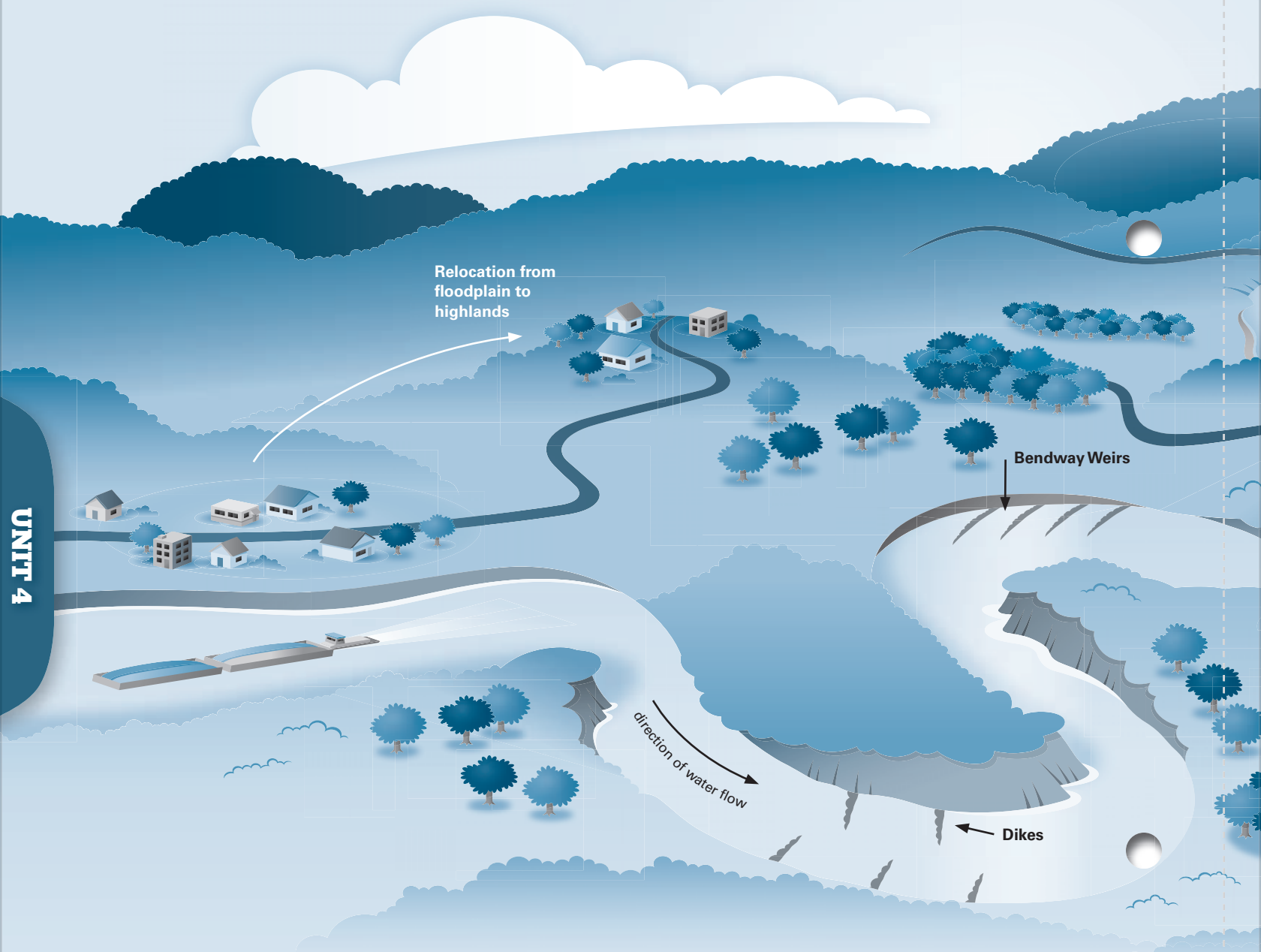

UNIT 4

Water Management Structures and Techniques

- **Relocating** people to higher ground helps protect homes and businesses when large floods inundate the floodplain.
- **Dikes (aka Wing Dams)** are structures that direct the flow of water. There are several types of dikes on the Upper Mississippi River.
- **Bendway Weirs** are stone structures placed underwater in the deepest part of river bends. They reduce the need for dredging and create river currents that are easier to navigate.
- **Off Bank Revetments** stabilize eroding riverbanks by placing rocks in the river parallel to the bank. This avoids the need to grade the bank and allows natural vegetation to grow.
- **Pile Dikes** are rows of wooden posts driven into the riverbed. As the river flows through them, it makes patterns in the riverbed and collects wooden debris, which create habitat for fish.
- **Chevron Dikes** are arch-shaped rock structures that point upstream. They work with the flow of the water to create fish habitat.
- **Locks and Dams** make the Upper Mississippi River navigable year-round by maintaining a channel of at least nine feet in depth.
- **W Dikes** help control sediment distribution and maintain navigable channel depths.
- **Notched Dikes** allow water and sediment to flow near riverbanks, which can create habitats for fish and wildlife, such as islands and sediment deposits.
- **Bullnoses** protect islands from erosion and create habitat for aquatic life.
- **Wetlands** absorb floodwaters like a sponge. Preserving or restoring wetlands helps prevent major floods.
- **Hard Points** are short rock structures that protect riverbanks from erosion and create fish habitat.

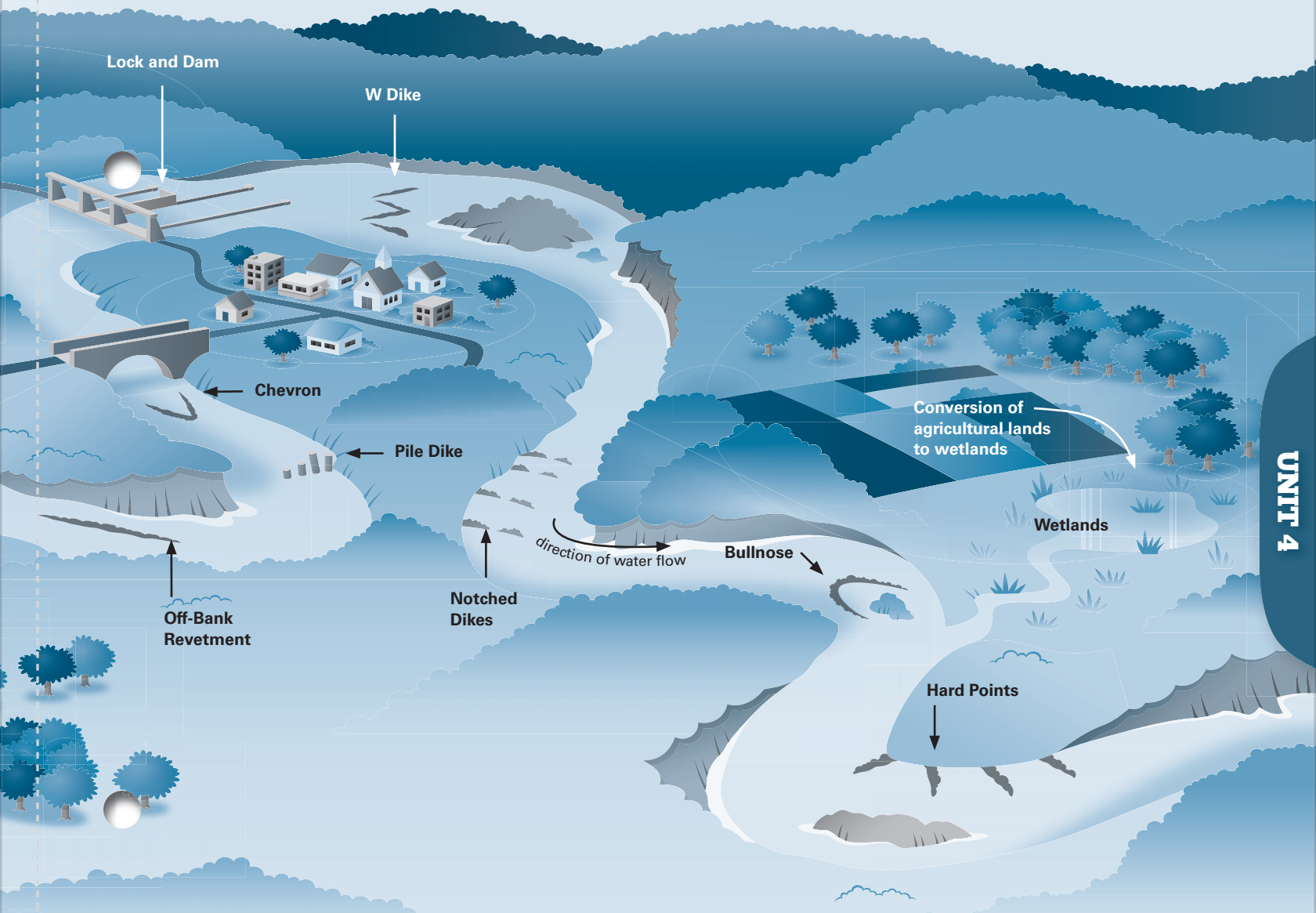

Lesson 4.4

Discussion (60–90 minutes)

Remind students that earlier in this unit we talked about early navigation and how much human effort was required to get up and down the river. After the steamboat was invented, travel on the Upper Mississippi River was faster and easier, but travel was often delayed and even prevented by the unpredictable nature of the river and its changing water levels.

Ask students if they have heard the expression “water seeks its own level” and what they think it means. Explain

how gravity allows water to flow downhill. Locks use gravity to raise or lower the water, much like filling and emptying a bathtub.

Use the online video and animations from the sources listed below to allow students to explore how locks and dams work in more detail.

Finally, discuss how locks changed navigation on the Upper Mississippi River, including their impact on wildlife and the environment.

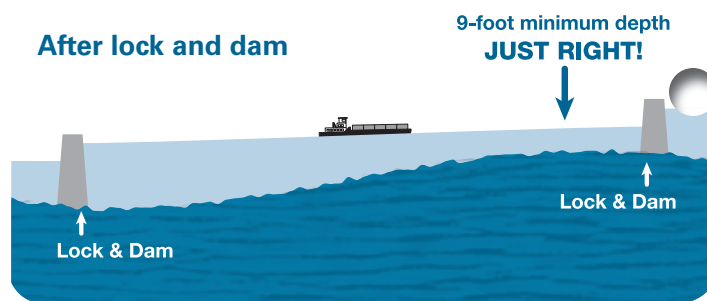
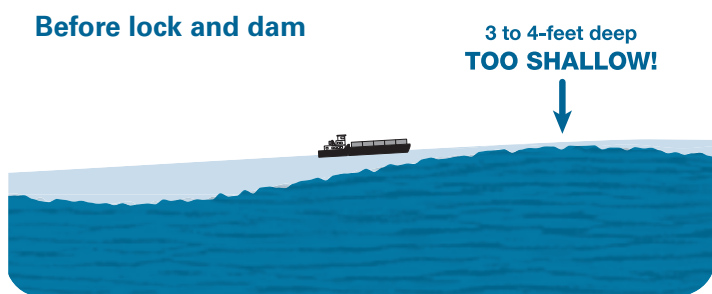

Welcome to Our Mississippi

File Edit View Favorites Tools Help

<http://www.OurMississippi.org>

Online sources

- 30-minute video (in three 9- to 10-minute segments) about the U.S. Army Corps of Engineers' mission on the Upper Mississippi River from the Pentagon Channel. Go to www.youtube.com and search for the titles of the following segments:
RECON The Big Muddy
- Live cam of real-time images from Lock and Dam 25 on the Mississippi River near Winfield, Missouri. Go to <https://webcam.crrel.usace.army.mil>
- Flash animation showing how locks work. Go to www.teachengineering.com and search keywords **locks and dams**
- 10-minute video of a dredge boat in action at PBS station KETC's website. Go to www.ketc.org and search keywords **dredge video**. Then choose “dredge boat” from the list. This video is also available on www.youtube.com

Locking Through

The three steps in the “LOCKING THROUGH” process are shown below. Notice that the water flows moves by gravity, not pumps.

Teacher Tip

Use this diagram as the answer key for page 271 activity.

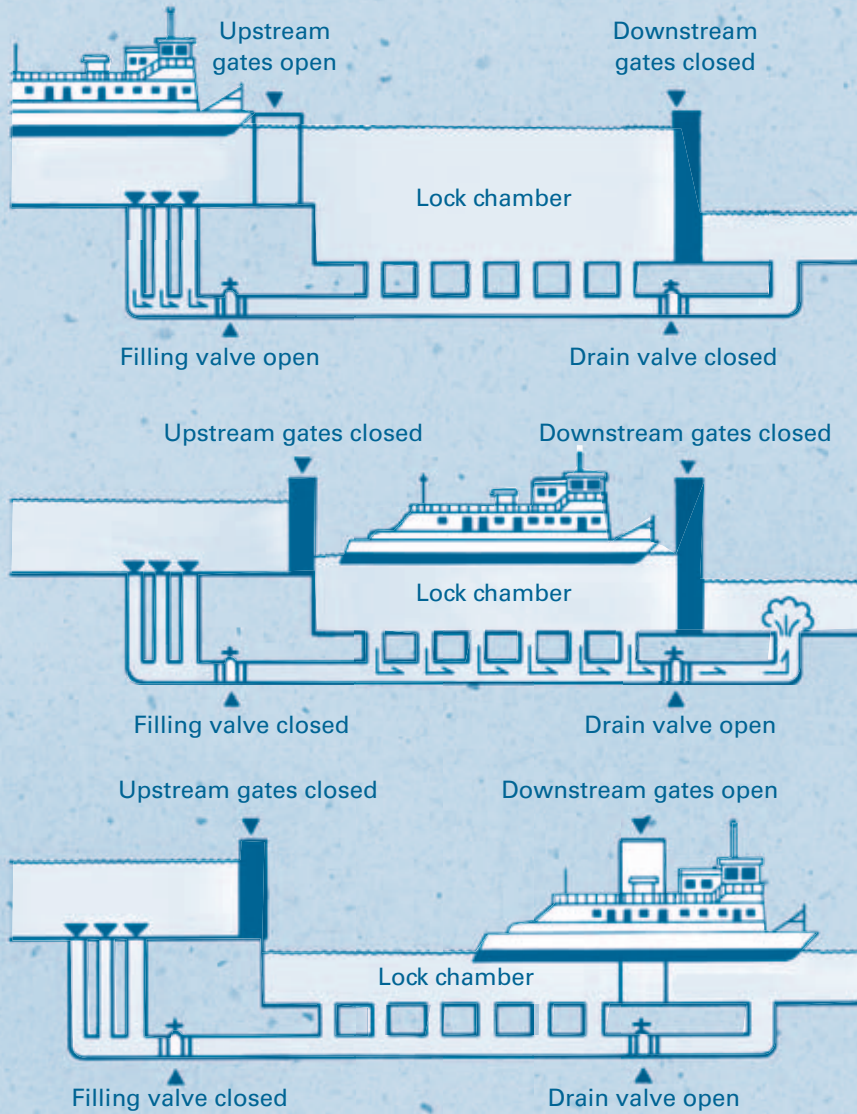

For a boat going downstream (towards the mouth of the river), the lock chamber is first filled by opening the filling valve. The drain valve and upstream and downstream gates are closed, so the level of the water in the chamber rises to the upstream level. The upstream gate opens and the boat moves in.

To lower the boat, the gates are closed behind it, the filling valve is closed, and the drain valve is opened. The higher water in the lock chamber drains to the downstream level within minutes. The downstream gate is then opened and the boat moves out on the lower water level. The process is reversed for a boat going upstream (towards the headwaters).

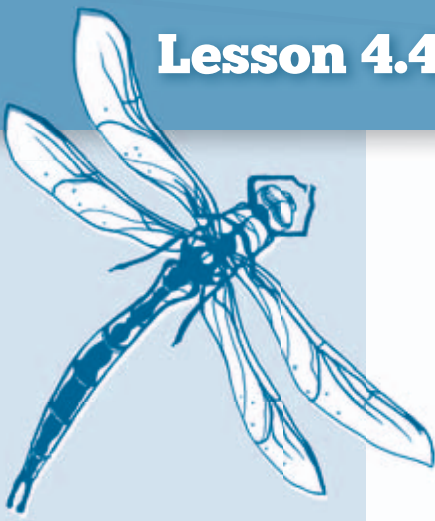

Grades

5-6

Group or
individual activity

2 SESSIONS

- 15 min. for preparation
- 1 hour for student activity

What you'll need

- Grease pencil or permanent marker
- 2 half-gallon milk or juice cartons
- Plastic container (about 18" x 24" x 6")
- Modeling clay
- Ruler (with centimeters)
- Scissors
- Water to fill plastic container 3 cc deep
- Pencil and paper
- Activity worksheets (pages 270-271)

Leveling the Water

This activity allows students to demonstrate how gravity raises or lowers water using milk cartons and water. This activity will help students understand how water levels change without pumps, allowing watercraft to move from one lock to the next. Students also use math to measure volume and compare amounts at the start and end of the activity. Then they report their findings in an essay.

Do This*Part 1:*

1. Have students work in pairs to do this activity.
2. After they complete step 5, have students calculate the volume in each carton and record their findings on the Student Activity Worksheet on page 270.
 - Measure the depth of each carton and calculate the volume in cubic centimeters (cc). $\text{Volume} = \text{length} \times \text{width} \times \text{depth}$.
 - Compare the difference in volume between cartons A and B.
3. Have the students explain the outcomes in a three-paragraph essay.

Part 2:

Ask students to put the images in order and complete the labels in the Student Activity Sheet on page 271.

Experiment with Water Levels

1



Cut the tops off the two milk cartons (Cartons A and B), about 12 centimeters (cm) from the top.

2



Poke one hole 1 cm from the bottom of each carton.

3



Cover the hole with clay.
 a. Measure and draw a line inside 4 cm from the bottom of Carton A.
 b. Measure and draw a line inside 12 cm from the bottom of Carton B.

4

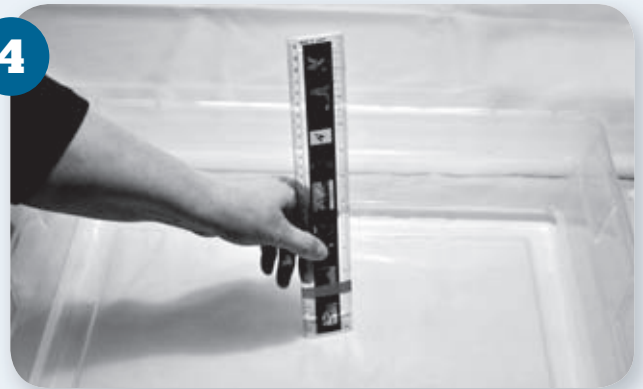

Pour water into the container 5 cm deep.
 a. Pour water up to the 4 cm line in Carton A.
 b. Pour water up to the 12 cm line in Carton B.

5



Place both cartons inside the container.
 a. Remove the clay from Carton A. Make sure the hole is open. Wait about 5 minutes and measure inside Carton A. Record water level.
 b. Remove the clay from Carton B. Make sure the hole is open. Wait about 5 minutes and measure inside Carton B. Record water level.



Activity may be completed as a demonstration project, individually, or in collaborative pairs. For the assessment, students should draw their conclusions independently.



Be a Water Leveler

Name _____ Date _____

Once you have demonstrated how water seeks its own level, answer the following questions.

Record your water data

Beginning depth of water in carton A _____ cm

Beginning volume in carton A _____ cc

(volume = _____ length x _____ width x _____ depth)

Beginning depth of water in carton B _____ cc

Beginning volume in carton B _____ cc

(volume = _____ length x _____ width x _____ depth)

Difference in volume of water in carton A and B _____ cc

Ending volume in carton A _____ cc

Ending volume in carton B _____ cc



Write a three-paragraph essay describing the outcome of your experiment. Use the data you gathered in your essay. You may need extra paper to complete this assignment.



Get Ready

Have students play the virtual lock game with the U.S. Army Corps of Engineers' Bobber the Water Safety Dog. Go to www.bobber.info and choose **Lock Game**.

Number these illustrations in correct order and complete the labels by circling the words open or closed next to all gates and valves.

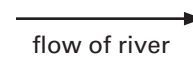

#

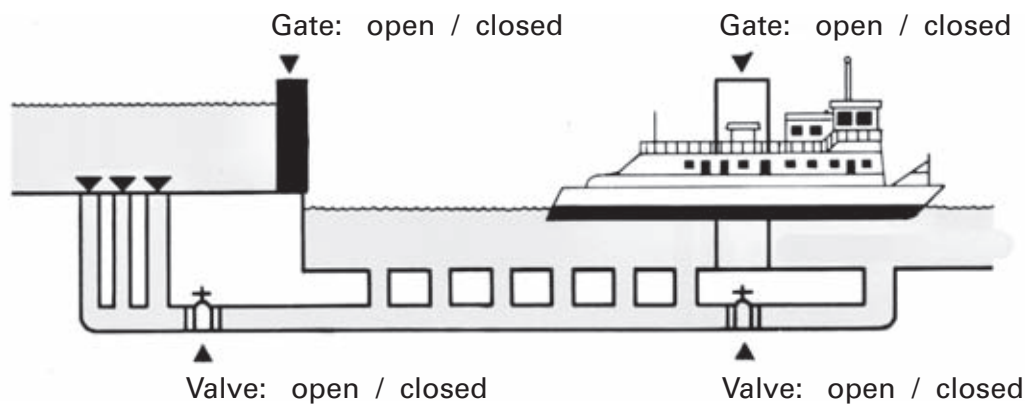

#

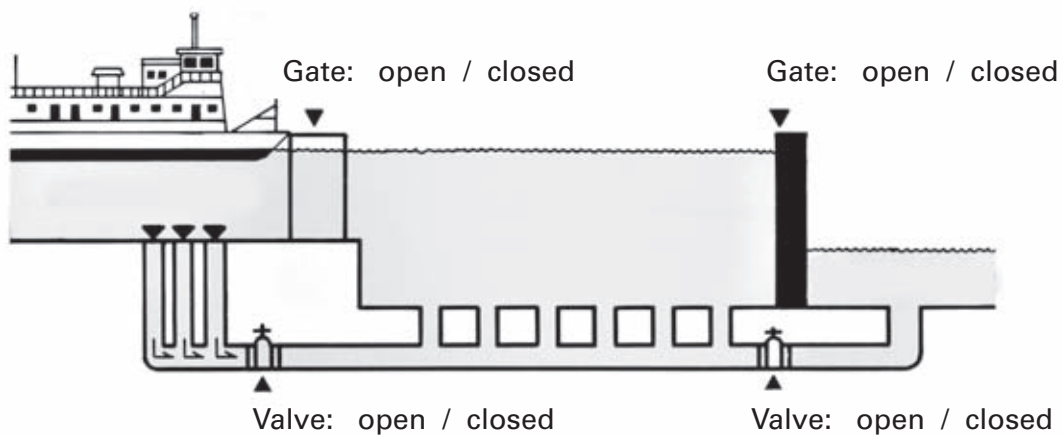

#

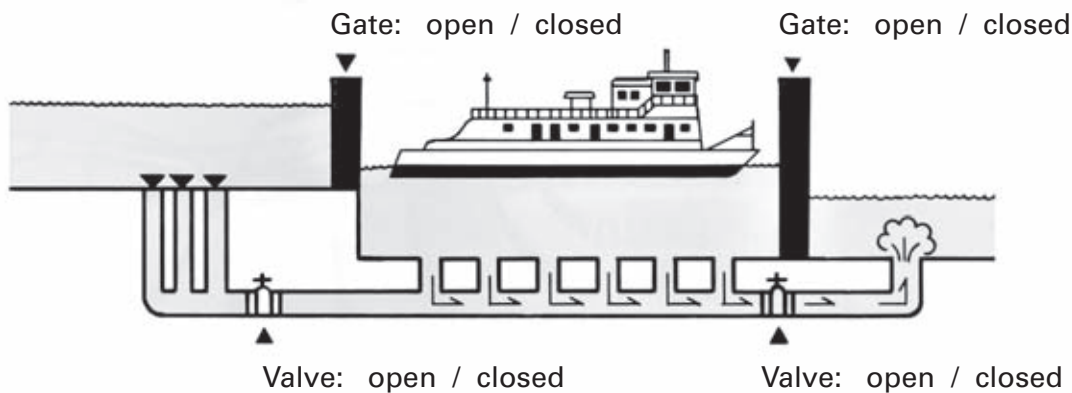



Fast Facts

◆ Illinois Waterway

- The Mississippi River is not the only major river that was dammed during the New Deal.
- The Illinois Waterway features eight navigation locks and dams that were constructed during the 1930s.
- The Illinois River drains 30,000 square miles of the Upper Mississippi River watershed.

◆ Melvin Price Locks and Dam

- Melvin Price Locks and Dam was the first replacement structure on the Upper Mississippi River nine-foot navigation project. It replaced Lock and Dam No. 26, which was demolished in 1990.
- It is named after Illinois Congressman Charles Melvin Price.
- Every year, more than 8,000 vessels and over 60 million tons of cargo pass through Melvin Price Locks and Dam.
- Although located on the Mississippi River, Melvin Price Locks and Dam controls the water level of the lower 80 miles of the Illinois River.

Extension Suggestions



~ Career launch

Invite a local **Lock Master** to speak to the class. Ask students to research the field and prepare questions in advance. See *A1: Career Launch* on page 312 for career information and professional associations.

~ Get out!

- Go watch a real lock at work.
- Tour a lock and dam facility.
- Get in a canoe or sailboat and go locking through (you should be an experienced paddler to go through by yourself).

~ Express yourself!

- Build your own lock and dam model or contact the U. S. Army Corps Engineers office near you to see if they have a model you can test.
- Make an engineering drawing of your lock and dam.

Welcome to Our Mississippi

File Edit View Favorites Tools Help



http://www.OurMississippi.org

~ Learn more online

Visit the **National Park Service** (www.nps.gov)
Search keywords: **Locks and Dams**

The **U.S. Army Corps of Engineers** is responsible for operating and maintaining all locks and dams along the Mississippi River. Learn about Mississippi River Locks and Dams operated by the Corps at www.mvp.usace.army.mil
Search keywords: **Locks and Dams**

Study locks and dams at **Teach Engineering** (www.teachengineering.com)
Search keywords: **Dams**



To Market! To Market!

Our Inland Waterway System

Introduction

Lesson 4.5, explores the role of the Mississippi River as part of the Inland Waterway system and its role as a vital economic artery. Students read a navigation chart and plan a journey from the Atlantic Ocean through the Saint Lawrence Seaway to the Gulf of Mexico.

Background

The Mississippi River is the heart of a vast system of inland waterways that connects over 25,000 miles of navigable waters in the United States, including the Illinois Waterway, the navigable Missouri and Ohio Rivers, and the Intracoastal Waterway. It forms most of a waterway linking the Great Lakes-St. Lawrence Seaway with the Gulf of Mexico.

STANDARDS CORRELATION

Students use what they learned about Mississippi River navigation and commerce in previous lessons to plan a virtual trip on the Inland Waterway System. This activity allows them to practice mapping, math, and computer skills as well as language arts.

~ Unit 4 goal reminder

Explore the Mississippi River at work and how it has changed over time

~ Lesson goal

Understand the river's role as a vital economic interstate

~ Lesson objectives

- Learn which products go up the river and which go down
- Compare modes of transportation: river, rail, and road
- Create a virtual trip from the Atlantic Ocean through the St. Lawrence Seaway to the Gulf of Mexico
- Read a navigational chart

~ Educational standards

- Science
- Social Studies
- Math
- Fine Arts
- Language Arts

~ What you'll need

- *Confluence: The River Heritage of St. Louis* Video
- Highlighters
- Computers
- Access to the Internet
- Microsoft PowerPoint software
- Wall map

~ How long it will take

- Activity 1: 1 hour
- Activity 2: 2.5 hours

~ What's next!

What does it mean to share the Upper Mississippi River?



Ships became able to travel from the Atlantic Ocean through the Saint Lawrence Seaway to the Gulf of Mexico after the Illinois and Michigan Canal was constructed in 1848. This canal connected Lake Michigan and the Illinois River. Later, locks and dams were built on the Illinois Waterway to improve navigation.

The Mississippi River serves as our nation's main transportation artery for gas, oil, fertilizer, industrial chemicals, lumber, pulp and paper, sand and gravel, steel, and coal. Corn, soybeans, and wheat are shipped from farms in the Midwest downriver to ports in south Louisiana and exported to foreign lands.

Large groups of barges are lashed together and pushed up and down the Mississippi River at 4 to 8 miles per hour by 10,000-horsepower towboats, delivering more than 400 million tons of bulk cargo each year.

These tows are an extremely efficient mode of transportation, moving about 22,500 tons of cargo as a single unit. They make it possible to move large volumes of bulk commodities long distances using less fuel and creating less pollution per ton mile than trucks or trains. They also make highways and railways less congested. A single 15-barge tow is equivalent to about 225 railroad cars or 870 tractor-trailer trucks. If the cargo transported on the inland waterways each year had to be moved by another mode, it would take an additional 6.3 million rail cars or 25.2 million trucks to carry the load.

This vital shipping channel is maintained by dredging. The Upper Mississippi River is made navigable by 29 locks and dams, which allow giant barges to travel as far north as Minneapolis. The U.S. Army Corps of Engineers is responsible for investigating, developing and maintaining the nation's water and related environmental resources.

However, modern navigation comes at both an environmental and financial cost. Maintaining and operating the locks and dams along the river takes a great deal of money, and dredging and damming the river causes environmental damage.

Sources: National Park Service, Texas Transportation Institute, and U.S. Army Corps of Engineers.

Fast Facts

◆ Hazardous Materials Spills

Barges spill fewer gallons of fuel per one million ton-miles.

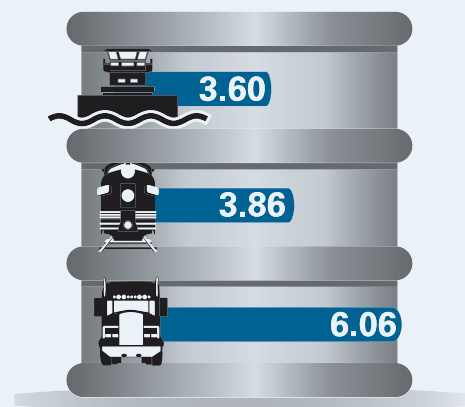

Rate of Spills in Gallons per Million Ton-miles

Spills of more than 1,000 gallons

Source: National Waterways Foundation. *Advantages of Inland Waterways Transport: Safeguarding Our Health and the Environment.*

Discussion (30 minutes)

You'll need

- *Confluence: The River Heritage of St. Louis* (see page 220 for more information about the video)
- Wall map

Show students Scene 4, "River Network of the Future" from *The River Heritage of St. Louis* video and discuss the goods and products that travel up and down the river. Use the wall map to discuss how boats can travel from the St. Lawrence River to the Gulf of Mexico.

Have students research the various products hauled on the Mississippi. Ask them which commodities go up the river (e.g., coal) and which ones go down (e.g., wheat) and why. Discuss and compare hauling products by river, rail, and road.

Need to Know

- **Coal** is the largest commodity by volume moving on the inland waterways. The country's electric utility industry depends on the inland waterways for over 20% of the coal they consume to produce electricity.
- **Petroleum** is the next-largest group, including crude oil, gasoline, diesel fuel, jet fuel, heavy fuel oils, and asphalt.
- Another large group includes **grain** and other **farm products**, most of which moves by waterway to ports on the Lower Mississippi River or Columbia River for export overseas. 60% of the country's farm exports travel through inland waterways.
- Other major **commodities** include aggregates, such as stone, sand, and gravel used in construction; chemicals, including fertilizers; metal ores, minerals, and products, such as steel; and many other manufacturers' products.

Fuel Efficiency

Barges move more tons of cargo per gallon of fuel.

Ton-miles Traveled per Gallon of Fuel

Source: National Waterways Foundation. *Advantages of Inland Waterways Transport: Safeguarding Our Health and the Environment.*

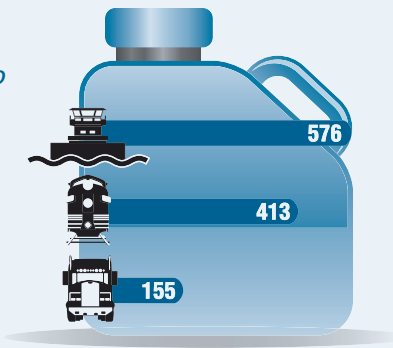

CO2 Emissions

Barges produce less CO2 emissions per million ton-miles than trains and trucks.

Tons of CO2 per Million Ton-miles

Source: National Waterways Foundation. *Advantages of Inland Waterways Transport: Safeguarding Our Health and the Environment.*

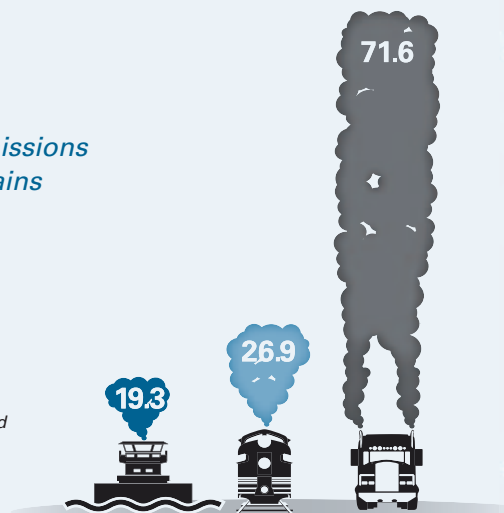

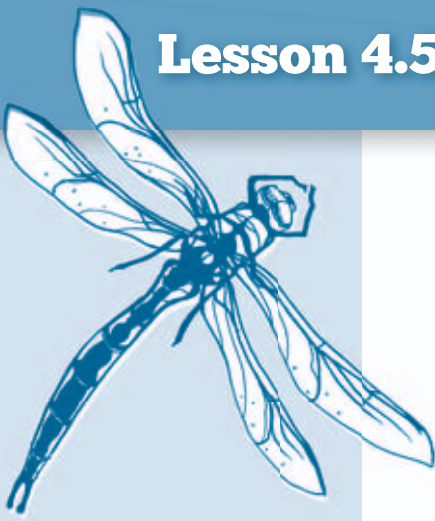

Grades
5-6

**Individual or small
group activity**

2.5 HOURS

- 30 minutes to explain assignment and answer initial questions (longer if unfamiliar with the software).

What you'll need

- Computers
- Microsoft PowerPoint software
- Wall map
- Internet

Plan a Virtual Trip on Inland Waterways

Students create a PowerPoint presentation of a virtual trip on inland waterways from the Atlantic Ocean through the Saint Lawrence Seaway to the Gulf of Mexico.

Do This

1. The students will create a PowerPoint presentation that is a virtual field trip: Trace the path from the Atlantic Ocean through the St. Lawrence Seaway to the Gulf of Mexico.
2. Break students into groups and assign each group a section of the voyage (e.g., Chicago to St. Louis, St. Louis to New Orleans).
3. Presentations may include (they should use their imaginations):
 - Products
 - Various watercraft
 - Water safety signs
 - Wildlife seen along the way
 - Ports of call
4. Each group will produce a PowerPoint presentation (or part of one) with pictures and/or graphics plus narrative in the form of words or audio.
5. Each group will present their slideshow to the class.



If PowerPoint is not an option, have students create a paper slide show using large index cards or half sheets of notebook paper.

Grades
7-12

Individual activity

Commercial fishermen catch over 11 million pounds of fish on the Upper Mississippi each year. They must know a great deal about fish behavior and habitat, state and federal regulations, and boat maintenance, operation, and navigation.

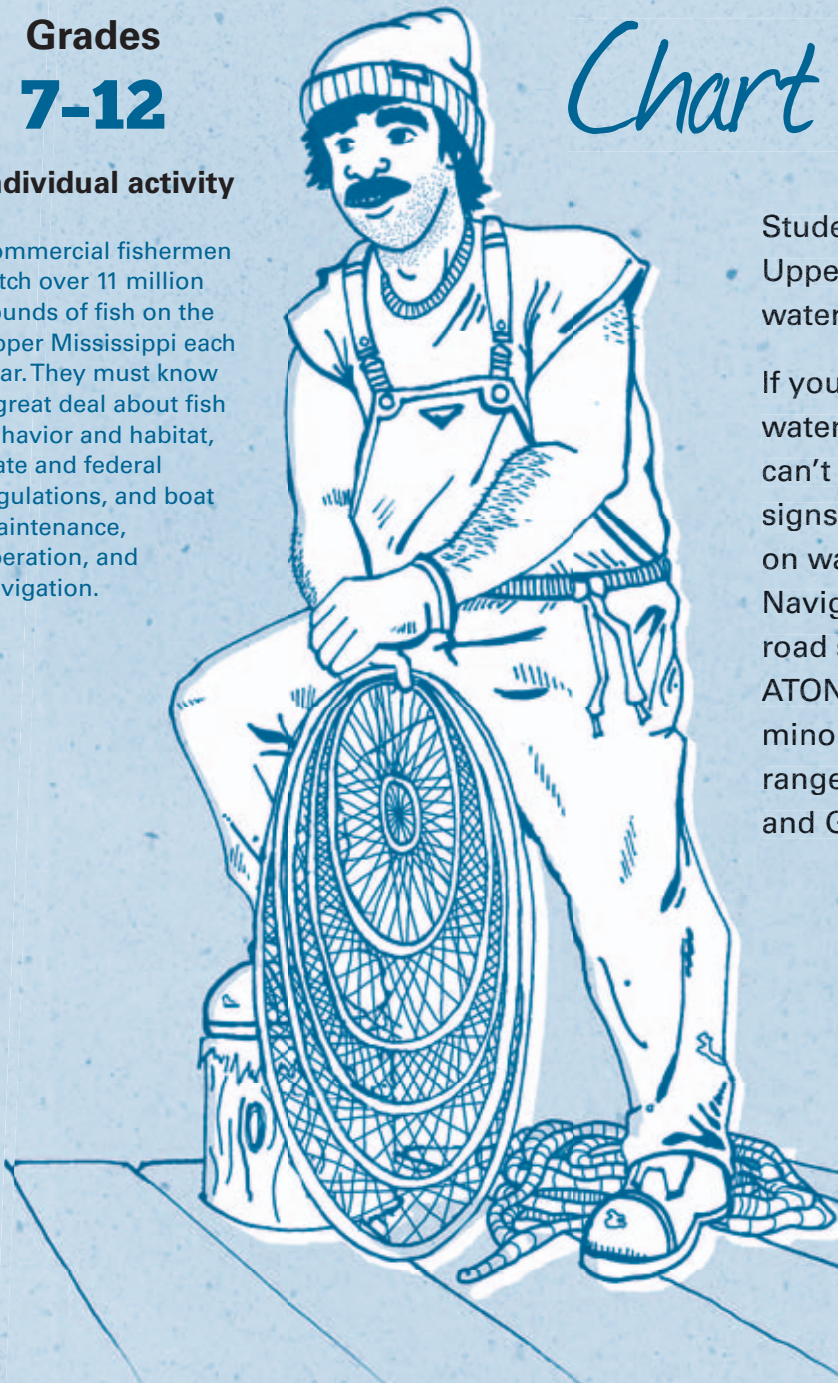

Chart Safe Water

Students use a navigation chart of the Upper Mississippi River to trace a safe water route.

If you travel by boat into unfamiliar waters or go out far enough that you can't see land, you must depend on signs just as you do on land. Signs on waterways are called Aids to Navigation (ATONs). These are the road signs of the water. Short-range ATONs include buoys, day beacons, minor lights, and lighthouses. Long-range aids include satellite beacons and GPS systems.

Have students use the navigation chart and legend on the next page (Map No. 57: River Mile 475 to 482) to determine the safest route past Horse Island. (Answer: They should draw a line between the red (shown in black) and green (white) buoys).

Then ask students to use the map and legend to answer the following questions on a separate piece of paper:

1. How many river miles between Lafarge Lights and Black Hawk Dock?
Answer: 1.4 river miles

2. Which way should you go around Horse Island? **Answer: Around its east side in between the red (shown in black) and green (white) buoys**
3. Can you anchor at the dotted line at Horse Island? **Answer: No**



Navigate the Mississippi River

Name _____ Date _____

Enlarged section of
Map No. 57 of the
Upper Mississippi
River (Miles 475-482)

I O W A
SCOTT COUNTY



HORSE ISLAND
UPPER LIGHT 477.2R

WALNUT GROVE

HARVEST STATES CO-OP
DOCK LIGHTS (2) 476.0R

BLACKHAWK DOCK
LIGHT 475.8R

HARVEST STATES CO-OP
LIGHTS (2) 475.7R

AMOCO DOCK
LIGHT 475.5R

LINWOOD

KOCH MATERIALS
LIGHT 475.4R

LINWOOD MINING AND
MINERALS LIGHT 475.3R

LAFARGE
LIGHTS (2) 474.6R

SCALE 1:31,680
1 INCH = 1/2 MILE

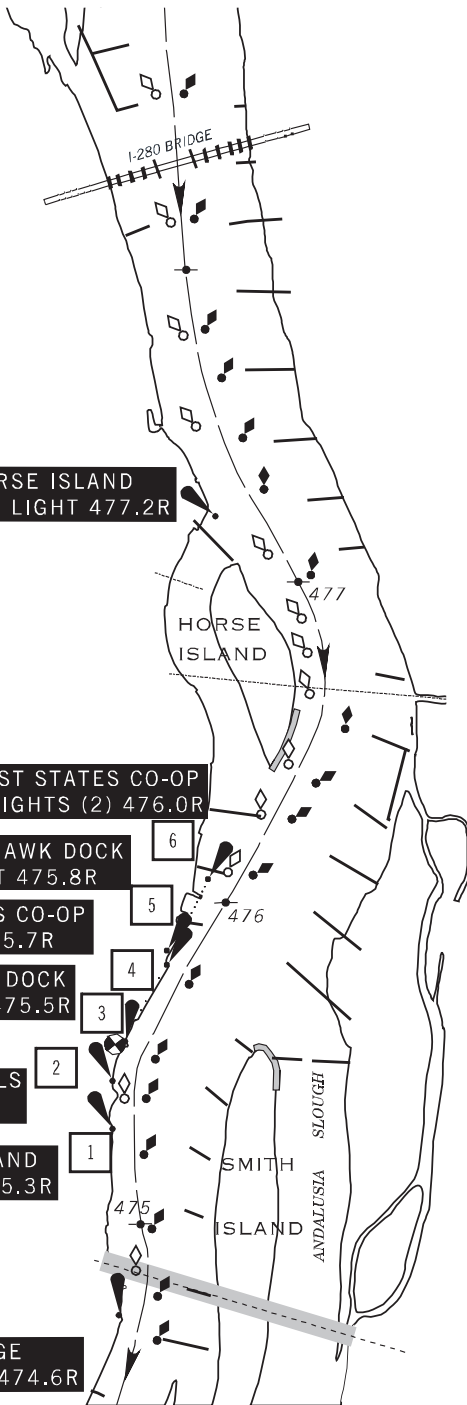
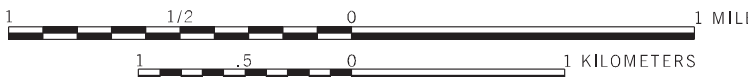

Use this navigation chart and legend to determine the safest downstream route past Horse Island. Remember, lights and buoys are the traffic signs on rivers. Your course should take you between the green (shown in white) and red (shown in black) buoys.

Highlight your route with a pen or highlighter. Answer the following questions on a separate piece of paper:

1. How many river miles between Lafarge Lights and Black Hawk Dock?
2. Which way should you go around Horse Island?
3. Can you anchor at the dotted line at Horse Island?

AIDS TO NAVIGATION

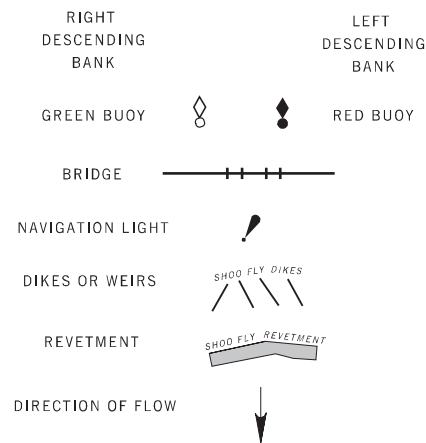

Grades
7-12

Individual
activity

Units to Carry
1,750 Short Tons of Dry Cargo

- 1 barge
- 16 rail cars
- 70 trucks



One loaded covered hopper barge carries 58,333 bushels of wheat, enough to make almost 2.5 million loaves of bread.

Units to Carry
27,500 Barrels of Liquid Cargo

- 1 barge
- 46 rail cars
- 144 trucks



A loaded tank barge carries 27,500 barrels of gasoline, enough to keep about 2,500 automobiles running for an entire year.

How Much Does It Carry?

(Standard modal freight unit capacities)

What do the numbers tell us?

That depends on whose numbers you use. Research data on barge, rail, and truck comparisons to see how many different sets of statistics you can find. Try to locate sources with different points of view, such as industry groups versus environmental organizations. These sources below are a good place to start.

- Izaak Walton League of America (www.iwla.org)
- National Waterways Foundation (www.nationalwaterwaysfoundation.org)
- National Audubon Society (www.audubon.org)
- Nature Conservancy (www.nature.org)
- Sierra Club (www.sierraclub.org)
- Texas Transportation Institute, Texas A&M University (tti.tamu.edu)
- U.S. Army Corps of Engineers (www.usace.army.mil)
- U.S. Department of Transportation Maritime Administration (www.marad.dot.gov)
- U.S. Fish & Wildlife Service (www.fws.gov)
- Waterways Council, Inc. (www.waterwayscouncil.org)

Extension Suggestions



~ Career launch

Invite a local **towboat captain** to speak to the class. Ask students to research the field and prepare questions in advance. See *A1: Career Launch* on page 312 for career information and professional associations.

~ Get out!

- Take a real field trip up the Mississippi River.
- Go watch a working dock in action.

~ Express yourself!

Imagine what it would be like to take your virtual trip and write a fictional travelogue. Use Mark Twain's *Life on the Mississippi* as inspiration.

Welcome to Our Mississippi

File Edit View Favorites Tools Help



<http://www.OurMississippi.org>

~ Learn more online

Learn how navigational techniques change when people travel by land, sea, air, or space at the **Teach Engineering** website (www.teachengineering.org)
Search keywords: **navigation**

Learn about nautical charts on the **National Oceanic and Atmospheric Administration (NOAA)** website. Go to www.noaa.gov and search keywords: **nautical charts**

Go to the **Department of Commerce** website to learn more about commerce in the U.S.. Go to www.commerce.gov

Learn about the role of the **U.S. Coast Guard** (www.uscg.mil)